

Intelligent Irrigation System Using IOT

Linganna Banothu, Sreelatha Pulipaka

Department of Electrical and Electronics Engineering

Sree Dattha Group of Institutions, Hyderabad, Telangana, India.

ABSTRACT

The purpose of this project is to design a system which monitors and controls the water flow to an irrigation system using Mobile Phone through WI-FI and monitoring temperature and humidity. This can be achieved by the use of soil moisture sensor, which senses the water content in the soil. This sensor output is given to a Microcontroller based control system for further data processing. This project also consists of IoT module for remote monitoring and control of water supply to irrigation system. Whenever the soil moisture content goes below some predefined level, and then this information is sent through WI-FI. Based on the command received from IoT the Microcontroller switches ON or OFF the electrical water pump. The design of this system is very much sensitive and should be handled with utmost care because the microcontroller is a 5 volts device and it is employed to monitor the operation of high voltage water motor. So, every small parameter should be given high importance while designing the interfacing circuit between the controller and the water motor.

Keywords: Irrigation, WI-FI, Mobile phone.

1. INTRODUCTION

INDIAS major source of income is from agriculture sector and 70% of people depend on the agriculture, most of the irrigation systems uses traditional methods which are operated manually. Two scare and valuable resources of irrigation that is water and energy are not efficiently utilized by the current irrigation system. Today's advanced society has turned into a digital world through the contribution of technology, now we are living in such an era where technology is studied to improve our life style. Hence to make life simpler and convenient SMART WATERING SYSTEM had been introduced. A model of controlling irrigation facilitates to help millions of people.

Smart watering system can be defined as the science of artificial application of water to the soil depending on the soil moisture content. With the advent of open source arduino boards along with the moisture sensor, it is viable to create devices that can monitor the soil moisture content and accordingly irrigating the fields or the land scape when needed. The proposed system makes use of microcontroller ATMEGA328P on Arduino uno platform and IOT which enables farmers to remotely monitor the status of water level in the soil by knowing the sensor values thereby, making the farmers work much easier as they can concentrate on other farm activities.

The agricultural sector has its largest contribution in the Indian economy. Agriculture uses 85% of available freshwater resources worldwide, and this percentage will continue to be dominant in water consumption because of population growth and increased food demand. As our country is an agriculture-oriented country and the rate at which water resources are depleting is a dangerous threat to the mankind. Hence there is a need of efficient way of irrigation.

In the present era, the farmers have been using irrigation technique through the manual control in which they irrigate the land at the regular interval. Irrigation has always been an ancient practice which has evolved through so many stages over the years. Our ancestral farmers in a bid to irrigate their farm sought for various methodologies they are manual irrigation by using buckets and watering cans, flood irrigation, drip irrigation, sprinkler irrigation was and are still being used today. The main reason for our current condition of agriculture is lack of rains & scarcity of land reservoir water. Rain

plays the key role in deciding the future of these crops as well as the farmers every year. The over utilization of ground water has drastically reduced the ground water level in the last 15 years. So, it is the need of hour to utilize each and every drop of water wisely so that it can also be used by our coming generations also. The existing systems has several limitations; leaching off of soil nutrients, erosion due to flooding, loss of water from plant surfaces through evaporation, water wastage which can result to water scarcity in drought areas and production of un healthy crops. These problems can be rectified if we use microcontroller based automated irrigation system in which the irrigation will take place only when there will be acute requirement of water, maintaining proper amount of water level in the soil is one of the necessary requirements to harvest a good crop that can be a source of various types of nutrients whether micro or macro for their proper growth. This project is designed to develop an automatic irrigation system which controls the watering in the fields depending on moisture content of the soil. The main advantage of this project is to reduce human intervention and still ensure proper irrigation. The aim of this project is to provide water to the plants or paddy fields automatically using microcontroller (Arduino Uno). There are many timer-based devices available in the market which waters the soil on a set interval. But they do not sense the soil moisture and the ambient temperature to know if the soil actually needs watering or not. The control unit of the system receives the signal of varying moisture condition of the soil through the sensing arrangement.

The system has a network of soil-moisture sensor, an LDR sensor, humidity and temperature sensor. These sensors outputs are fed to the microcontroller which will trigger the water pump whenever necessary. And also, we should develop some new methods that use their new able sources of energy. The development to these new techniques is going to reach our goal of sustain able development as well as to cut off the emission of greenhouse gases to a minimum level. As the name of our project that is "IOT" which uses power for the functioning of the project and to save electricity. This technique will be a very good option for the small and medium farmers who suffer just because of failure of crops that takes place every year. The implementation of this technology has a wide scope in the nearby future. Moreover, implementing IOT in the system allows the user to control and monitor the scenario remotely. The inter connected objects referred as Internet of Things (IOT) is continuing to evolve offering more control over our living environment and allowing more ease in doing things. Many consider this as the next big horizon in the evolution of the Internet. IOT has the capability of collecting, storing, analyzing and distributing data among diverse interfaces, apps and devices.

The freedom for real-time application of data and data-driven insights has become easier than ever before. The status of the soil as well as the values of all the sensors will be transmitted over the internet and displayed on a web page which will help the user to globally access the values by any digital device like mobile phones. The smart sensors placed in the agriculture field sare also capable of real time notification about the moisture level in land sand can prevent wastage of water. This capability can be further used if the real time sensor data can trigger the water pump by switching it off or on depending on moisture content of the soil. The system is powered by photovoltaic s and has a wireless communication link with the control unit.

2. LITERATURE SURVEY

INDIA is one of the scare water resources in 13 countries in the world, due to low utilization of water resources our country is facing the risk of overheating. In order to effectively scale back the impact of inadequate water resources on INDIA's economy from fashionable agricultural cultivation and management prospective, online with essential principles of web, with device technology, this paper proposes exactitude agriculture irrigation system, and focuses on the hardware design, specification and code method management of the irrigation system. The newer scenario of decreasing water tables,

drying up of rivers and tanks, unpredictable environment presents an urgent need of proper utilization of water. To cope up with this use of temperature and moisture sensor at suitable locations for monitoring of crops is implemented in [1]. An algorithm developed with threshold values of temperature and soil moisture can be programmed into a microcontroller-based gateway to control water quantity [2]. After the research in the agricultural field, researchers found that the yield of agriculture is decreasing day by day. However, use of technology in the field of agriculture plays important role in increasing the production as well as in reducing the extra man power efforts. Some of the research attempts are done for betterment of farmers which provides the systems that use technologies helpful for increasing the agricultural yield [3]. The use of remote switching and monitoring of irrigation system using smart phones to address the need of automatic control of the water is presented. The data about soil moisture, temperature and humidity is sent to the smart phone for the user to make the decision. [4]. In the studies related to wireless sensor network, researchers measured soil related parameters such as temperature and humidity. Sensors were placed below the soil which communicates with relay nodes by the use of effective communication protocol providing very low duty cycle and hence increasing the life time of soil monitoring system. The system was developed using microcontroller, sensors while the transmission was done by hourly sampling and buffering the data, transmit it and provide the necessary water [5]. A connection has been established between climate policies and water management. Water management can be affected by different variables such as the water demand from the different sectors or the consequences of some degrees of warming on hydrological resources. Climate change and its effects are a recurrent topic in research papers regarding water resources and agriculture. The possible consequences of global warming have led to the consideration of creating water adaptation measures to ensure the availability of water for food production and people and to maintain ecosystems [2]. Furthermore, the safety of the water to be consumed by humans and to be returned to the environment must be ensured. The possible risks of climate change are an increase in water shortage, the reduction of water quality, the increase in water and soil salinity, the biodiversity loss, the increase in irrigation requirements or the possible cost of emergency and remediation actions. These reasons have led to an increase in the number of studies focused on reducing water usage in irrigation processes. Some of these studies suggest the implementation of social, economic and climate change policies, as well as the implementation of technological innovations to improve water management.

The agricultural sector is one of the most important economic resources in these countries adding to the importance of managing well the available water resources to ensure the continuing of this economical sector. In India, 10% of the area of the country is covered by rice plantations [3]. Furthermore, 20% of the Indian population is below poverty levels and 15% is food insecure. Therefore, low food production affects both the population and the economy. In 2002, the monsoon season produced the least amount of precipitation in the last 130 years. That resulted in a loss of rice production due to the lack of fresh water. To determine the drought caused by anomalies in surface water, the Standardized Precipitation Evapotranspiration Index (SPEI) was utilized. These indexes and the information gathered from sensors that monitor the environment, the soil and the water can be utilized to determine the current state of the water and the possibility of covering all the freshwater needs. Countries with higher funds are already implementing systems for water management and water reuse aiming to optimize water usage and reduce the environmental impact caused by utilizing great amounts of water. However, some countries may find these solutions to be costly.

Commercial sensors for systems aimed for agriculture and its irrigation are very expensive, making it impossible for smaller farmers to implement this type of system on their farms. However, manufacturers are currently offering low-cost sensors that can be connected to nodes to implement low-cost systems for irrigation management and agriculture monitoring. Furthermore, due to the

interest in low-cost sensors for monitoring agriculture and water, new low-cost sensors are being proposed in researches such as a leaf water stress monitoring sensor [4], a multi-level soil moisture sensor comprised of copper rings placed along a PVC pipe [5], a water salinity monitoring sensor made with copper coils [6] or a water turbidity sensor made with colored and infrared led emitters and receptors [7].

Due to the recent advances in sensors for the implementation of irrigation systems for agriculture and the evolution of WSN and IoT technologies that can be applied in the development of these systems, we present a survey aimed at summarizing the current state of the art regarding smart irrigation systems. In this survey, we are going to provide an overview of the state of the research regarding irrigation systems. We will determine the parameters that are monitored in irrigation systems regarding water quantity and quality, soil characteristics, weather conditions, and fertilizer usage. We will provide an overview of the most utilized nodes and wireless technologies employed to implement WSN and IoT based smart irrigation systems. Lastly, we will discuss the challenges and the best practices for the implementation of sensor-based irrigation systems. Other, authors have performed studies with a focus on irrigation systems, water management or precision agriculture systems. However, the other available surveys on smart irrigation systems analyzed quite a few papers [8,9,10] and therefore do not provide an in-depth analysis of the state of the art regarding irrigation systems. Others are focused on specific aspects regarding irrigation such as software for irrigation systems, pivot-center specific irrigation systems or irrigation systems for greenhouses.

3. PROPOSED SYSTEM

The proposed system having two working units: one is pumping unit and other is smart irrigation unit. The proposed system will help us to improve the irrigation system using a natural renewable power source such as energy. We can find the level of the water in tanks in the fields, the temperature around, the humidity in the air by using respective sensors. The most important application of this project is to sense the moisture level in the soil. Whenever the moisture content of the soil is low, it automatically sends a signal to the Arduino Uno, this microcontroller will switch on the DC pump through a relay. This system also reduces the attention which saves a lot of time and effort to the human beings. Most of the electricity bill is also reduced as we are using energy.

We can conveniently check the temperature, humidity in the fields, moisture level of the soil and water level in the tanks from any location by using the Internet of Things (IOT). This system can also display the measured factors in an LCD. If the moisture level in the soil is adequate, then the microcontroller switches off the motor and thus stops watering the fields which results in the less requirement of water. Thus, this system clearly shows that it requires very less manual attention and also saves a lot of water. This proposed system can be easily affordable by any farmer. What it takes is just a smart phone and an internet connectivity.

Block diagram

This energy stored in the battery is converted in to 5 volts DC. From here, the system gets its power supply to the microcontroller. The Temperature sensor, Humidity sensor, Soil moisture sensor, Level indicator acts as the inputs to the microcontroller. These values are studied by the microcontroller and are displayed on the LCD screen.

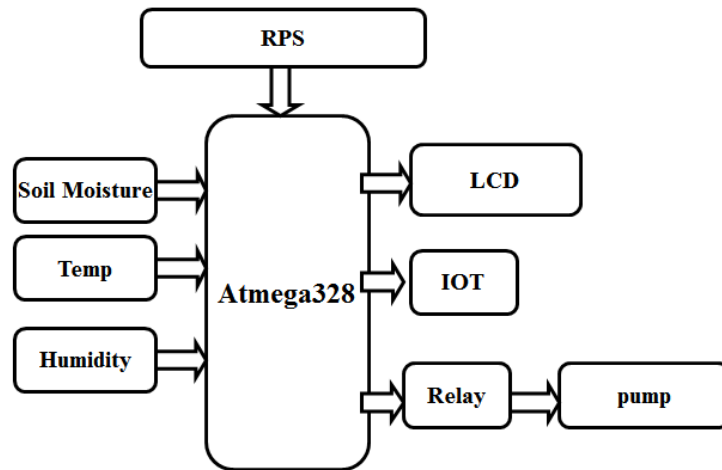

Fig. 1: Block diagram of proposed system.

Whenever the soil moisture level is low the relay is turned on and the DC motor is switched on to water the fields. If the moisture level in the soil is adequate, then the relay and Dc motor are turned off. Here, we are using IOT as a platform to write the code and also to display the measured values by the microcontroller.

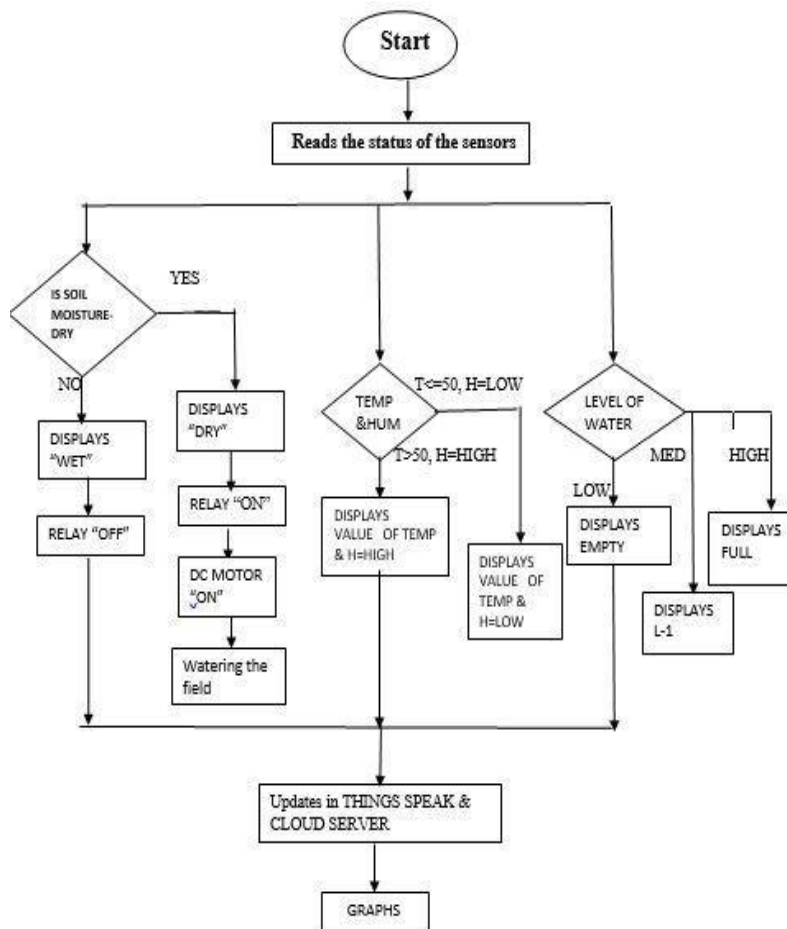

Fig. 2: Flow chart of proposed System.

Working

In any farm, the water supply is required as per the wet status of the soil. Depending on that the motor will automatically ON and OFF. The functionality of this project includes 4 factors i.e., Soil moisture, Temperature, Humidity & Level indicator. The wet & dry status of the soil can be measured by Soil moisture sensor. If the status of the soil is Dry, the relay will get automatically ON which is interfaced with motor to pump the water to fields and also displays in LCD. As soon as the status of the soil changes from dry to wet, the relay is switched off, also displays in LCD and this information is updated in graphs and cloud server through IOT module.

This system also reads the degree of temperature. When the temperature of the field or in the atmosphere is greater the 50 degree Celsius, displays present value & it will automatically get updated in cloud server through IOT module and if it is normal it will display in LCD. It also reads the status of humidity i.e., when the humidity is normal, it will display in LCD, if it is HIGH it will update in cloud server and displays. IOT Module which is present in the System will store the data continuously, this module requires Wi-Fi i.e., internet to upload the information in local server i.e., Things Speak. So, this set up requires Wi-Fi to upload data and this data will get updated in the form of graphs. Every person or Farmer can open certain respective links to monitor status of the fields.

3.1 Arduino IDE

What is Arduino IDE?

The Arduino Integrated Development Environment - or Arduino Software (IDE) - contains a text editor for writing code, a message area, a text console, a toolbar with buttons for common functions and a series of menus. It connects to the Arduino hardware to upload programs and communicate with them.

A program for Arduino hardware may be written in any programming language with compilers that produce binary machine code for the target processor. Atmel provides a development environment for their 8-bit AVR and 32-bit ARM Cortex-M based microcontrollers: AVR Studio (older) and Atmel Studio (newer).

3.2 Schematic diagram

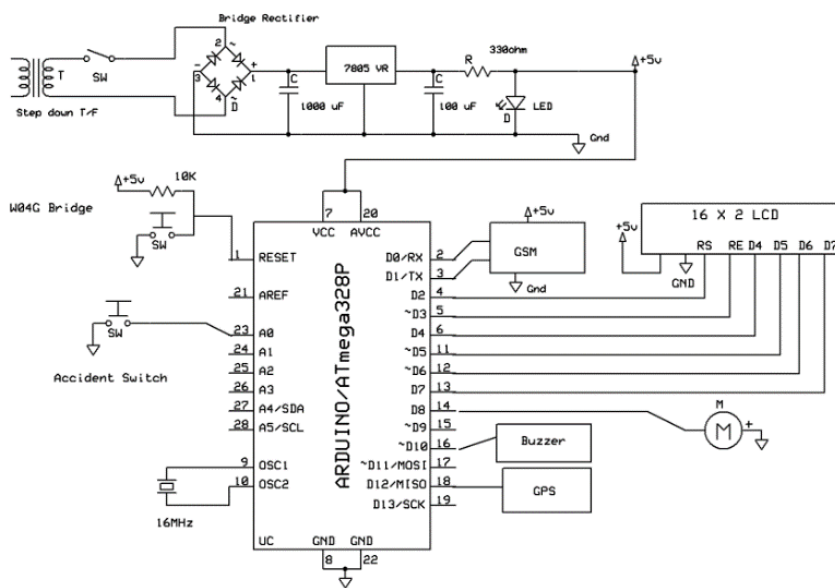
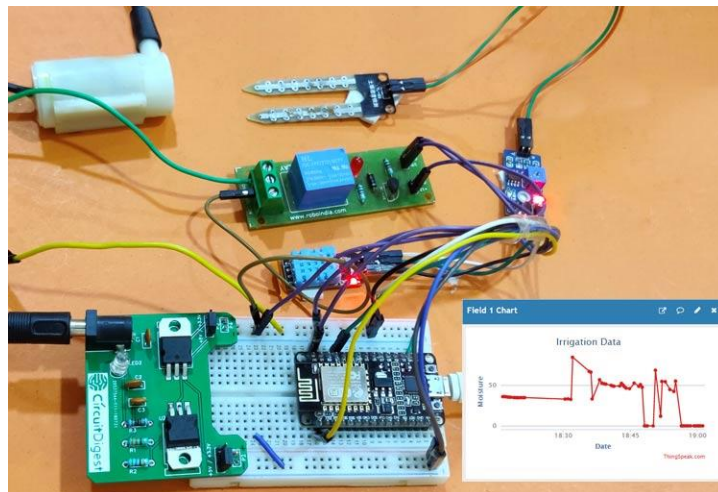
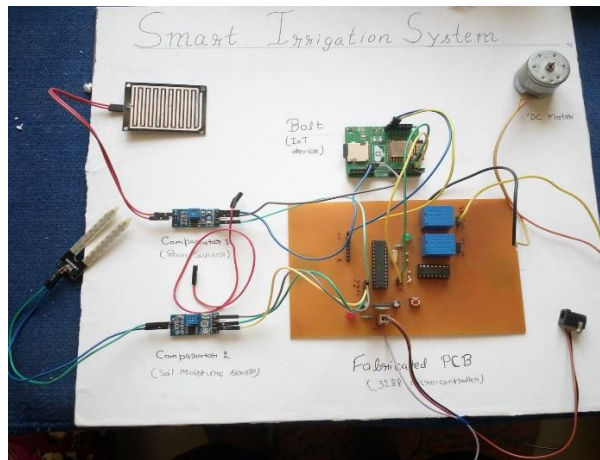

Fig. 2: Schematic diagram of proposed system.

4. Results



5. CONCLUSION

This innovative smart irrigation system is very beneficial for government as well as farmers. This is one of the best solutions for energy crisis and water consumption. The smart irrigation system reduces the human intervention during the irrigation of field and also optimizes the water usages. Once the system is installed, unutilized energy produced by the PV can also be linked with grid system which can be revenue source for farmers. Hence, this irrigation system is motivating farming in India and at the same time it is giving solution for the energy crisis.

Despite the fact that it required high initial investment for implementation of this system but in the long run this system is more economical than the conventional irrigation method. Government should also demonstrate this type of innovative system to motivate the farmers for adopting such type of system. Integrating features of all the hardware components used have been developed in it. Presence of every module has been reasoned out and placed carefully, thus contributing to the best working of the unit. Secondly, using advanced sensors with the help of growing technology, the project has been successfully implemented. Thus, the project has been successfully designed and tested.

5.1 Future Scope

Our project “Powered Smart Irrigation System” is mainly intended for detection of the moisture level of the soil. This project uses a Soil moisture sensor, Humidity and Temperature sensor (DHT11), Level sensor which are capable of detecting the moisture level of the soil, humidity and temperature

in the atmosphere of the fields and to detect the water level in the tanks respectively. This system uses Internet of Things as a platform to display the measured values. Not only on the even land, we can also use this project on uneven surfaces by taking few points in the fields as reference.

This project can be extended by adding GSM module and we can also control irrigation pump using mobile anywhere. It can also be extended as an Agricultural Robot which helps in harvesting, picking, weed control, autonomous mowing, pruning, seeding, spraying and shinning.

REFERENCES

- [1] Anitha. K “Automatic Irrigation System”, 2nd international conference Innovative trends in Science, Engineering & Management Nov 2017, ISBN :978-93-86171-10-8, ICITSEM-16
- [2] S. Harishankar, R. Sathish Kumar, Sudharsan K. P, U. Vigneshand T. Viveknath, “Powered Smart Irrigation System”, Advance in Electronic and Electric Engineering. Research India Publications, ISSN:2231-1297, Volume 4, Number 4 (2016), pp.
- [3] Pavankumar Naik, Arun Kumbi, Vishwanath Hiregoudar, Chaitra, Pavitra H, Sushma B S, Sushmita J H, Praveen Kuntanahal, “Arduino Based Automatic Irrigation System Using IOT”, 2017International Journal of Scientific Research in Computer Science, Engineering and Information Technology, ISSN:2456-3307 IJSRCSEIT | Volume 2.
- [4] Avinash Chitransh, Akash Sagar, Amit Kumar, “Automated Powered Irrigation System”, International Research Journal of Engineering and Technology (IRJET), ISSN: 2395-0056 Volume:03Issue:04|Apr-2016
- [5] Alok Gora and M.S Dulawat, “Powered Smart Irrigation System – An Innovative Concept”, Research Journal of Agriculture and Forestry Sciences, ISSN:2320-6063vol. 5(6). 15-19, June (2017)
- [6] Madhav Thigale, Y Patil, Akurdi, Rohit Alate, “Based Smart Irrigation System using GSM Module”, International Journal of Trend in Scientific Research and Development (IJTSRD) International Open Access Journal, ISSN No: 2456 - 6470 | Volume – 1 | Issue – 6 | Sep - Oct2017
- [7] Kavita Bhole, Dimple Chaudhari, “Powered Sensor Base Irrigation System” , International Research Journal of Engineering and Technology (IRJET), ISSN: 2395 - 0056 Volume: 03 Issue: 02 |Feb-2016.
- [8] Namrata Kataki, Pranjit Das, Manjay Chetri, Nihashree Sarma, Dipamani Pathak “IOT based Powered Automatic Irrigation System”, International Journal for Research in Applied Science & Engineering Technology (IJRASET)ISSN:2321-9653; Volume7 Issue VII, July2019.
- [9] Mounir Bouzguenda, S Rajamohamed, M H Shwehdi and Adel Aldalbahi, “powered smart irrigation system based on low-cost wireless network”, International Journal of Electrical Engineering & Education, June2019.
- [10] Srishti Rawal, “IOT Based Irrigation System”, International Journal of Computer Applications, ISSN: (0975 – 8887) Volume 159 – No 8, February2017.