

DISEASE DETECTION IN CHILLI PLANTS AND REMOTE MONITORING OF AGRICULTURAL PARAMETERS

V Chaitanya¹, Ganta Spandana², Timmapuram Abhishek², Thadakapally Sai Kiran²

^{1,2}Department of Information Technology

^{1,2}CMR Engineering College, Kandlakoya, Medchal, Hyderabad.

ABSTRACT

Early detection of the plant diseases is critical to avoid losses in the yield and quality of the agricultural product. The studies of the plant diseases have been widely researched to detect abnormality in plant growth using visually observable patterns on the plant. Plant monitoring and disease detection is needed to ensure sustainability in agriculture. However, it is usually very difficult to monitor the plant diseases manually as they require real-time and precision detection. Image processing is commonly used for the detection of plant diseases which involved image acquisition, pre-processing, segmentation, feature extraction and classification. In this paper, an Artificial Intelligence based image processing algorithm is proposed to detect diseases on a Chilli plant using its leaves images. The proposed system included ResNet CNN for feature extraction and classification.

Keywords: Plant diseases, plant monitoring, ResNet CNN.

1. INTRODUCTION

As a superpower with more than 20% of the world's total population, China has been facing the problem of insufficient arable land resources. According to the survey data of the Ministry of Agriculture, the proportion of cultivated land in China is even less than 10% of China's land area. According to statistics data, the mountainous area accounts for about two-thirds of the total land area in China, while the plain area accounts for only one-third. About one third of the country's agricultural population and arable land are in mountainous areas. This situation has resulted in the relatively poor production conditions of agriculture, forestry, and animal husbandry in China. According to the statistics of the Food and Agriculture Organization of the United Nations, the per capita cultivated land area in China is less than half of the world average level and shows a decreasing trend year by year. Once the natural disasters cause agricultural production reduction, it will seriously affect the output of agricultural products and agricultural development. So how to develop agriculture stably, especially in the complex environment, is extremely important for China.

Although with the development of science and technology, agricultural production is progressing. But due to various natural factors and non-natural factors, the yield of crops has not been greatly improved. Among the various factors, the largest proportion is the problem of crop diseases and insect pests. According to statistics, the area of crops affected by pests and diseases in China is as high as 280 million km² every year, and the direct yield loss is at least 25 billion kg [1]. In recent years, this problem is on the rise and seriously threatens the development of planting industry. Timely diagnosis and prevention of crop diseases has become particularly important. At present, agricultural workers often use books and network, contact local experts, and use other methods to protect and manage crop diseases. But for various reasons, misjudgements and other problems often occur, resulting in agricultural production is deeply affected.

With the rapid development of deep learning [2], especially in image recognition [3], speech analysis, natural language processing and other fields, it shows the uniqueness and efficiency of deep learning.

Compared with the traditional methods, deep learning is more efficient in the diagnosis of crop diseases in the field of agricultural production. The deep learning model can monitor, diagnose, and prevent the growth of crops in time. Image recognition of crop diseases and insect pests can reduce the dependence on plant protection technicians in agricultural production, so that farmers can solve the problem in time. Compared with artificial identification, the speed of intelligent network identification is much faster than that of manual detection. And the recognition accuracy is getting higher and higher in the continuous development. The establishment of a sound agricultural network and the combination of Internet and agricultural industry can not only solve the problems related to crop yield affected by diseases and insect pests, but also be conducive to the development of agricultural informatization [4].

2. LITERATURE SURVEY

Srivastav et al. focused on a pest control and monitoring system for efficient sugarcane crop production, which is a staple crop grown in Pune. The main pests that affect sugarcane are top shoot borer, stalk borer, rood borer and sugarcane wooly aphid. Transmission and reception of field data is through ZigBee 802.15.4 digital communication device standard. The system covers large areas with very low energy consumption.

Athanikar et al. described a neural network-based detection and classification of Potato leaf samples using Segmentation of K-Means Clustering. Algorithms are developed to acquire and process colour images of single leaf samples. The classification is carried out using different types of features sets, viz., colour, texture, and area. Classification accuracies of over 92% are obtained for all the leaves samples (healthy and diseased) using all the three feature sets.

Wang et al. recognized method to realize plant image diseases, four kinds of neural networks including backpropagation (BP) networks, radial basis function (RBF) neural networks, generalized regression networks (GRNNs) and probabilistic neural networks (PNNs) were used to distinguish wheat stripe rust from wheat leaf rust and to distinguish grape downy mildew from grape powdery mildew based on color features, shape features and texture features extracted from the disease images. The results showed that identification and diagnosis of the plant diseases could be effectively achieved using BP networks, RBF neural networks, GRNNs and PNNs based on image processing.

Samantha et al. proposed image processing methodology to detect scab disease of potato. In this paper first, the captured images are collected from different potato field and are processed for enhancement. Then image segmentation is carried out to get target regions (disease spots). Finally, analysis of the target regions (disease spots) based on histogram approach to finding the phase of the disease and then the treatment consultative module can be prepared by on the lookout for agricultural experts, so plateful the farmers.

Too et al. focused on fine-tuning and evaluation of state-of-the-art deep convolutional neural network for image-based plant disease classification. An empirical comparison of the deep learning architecture is done. The architectures evaluated include VGG 16, Inception V4, ResNet with 50, 101 and 152 layers and DenseNets with 121 layers. The data used for the experiment is 38 different classes including diseased and healthy images of leafs of 14 plants from plant Village. In this experiment, DenseNets has tendency's to consistently improve in accuracy with growing number of epochs, with no signs of overfitting and performance deterioration.

Mohanty et al. used a public dataset of 54,306 images of diseased and healthy plant leaves collected under controlled conditions, in this work trained a deep convolutional neural network to identify 14

crop species and 26 diseases (or absence thereof). The trained model achieves an accuracy of 99.35% on a held-out test set, demonstrating the feasibility of this approach. Overall, the approach of training deep learning models on increasingly large and publicly available image datasets presents a clear path toward smartphone-assisted crop disease diagnosis on a massive global scale.

Dyrmann et al. presented a method that is capable of recognising plant species in colour images by using a convolutional neural network. The network is built from scratch trained and tested on a total of 10,413 images containing 22 weed and crop species at early growth stages. This includes images taken under controlled conditions about camera stabilisation and illumination, and images shot with hand-held mobile phones in fields with changing lighting conditions and different soil types. For these 22 species, the network can achieve a classification accuracy of 86.2%.

Sa et al. presented a novel approach to fruit detection using deep convolutional neural networks. The system builded an accurate, fast and reliable fruit detection system, which is a vital element of an autonomous agricultural robotic platform; it is a key element for fruit yield estimation and automated harvesting. Recent work in deep neural networks has led to the development of a state-of-the-art object detector termed Faster Region-based CNN (Faster R-CNN). We adapt this model, through transfer learning, for the task of fruit detection using imagery obtained from two modalities: colour (RGB) and Near-Infrared (NIR). Early and late fusion methods are explored for combining the multi-modal (RGB and NIR) information.

3. PROPOSED SYSTEM

3.1 Crop Disease Recognition Model

Crop disease datasets are pre-processed and uploaded to ResNet CNN for feature extraction. On the other hand, leaf images are also pre-processed and uploaded to ResNet CNN for testing. The leaf images and the crop disease datasets are compared to the trained features which are already trained with the plant diseases. The extracted features have some loss computation and accuracy. The comparison graph could predict the classes of the plant disease.

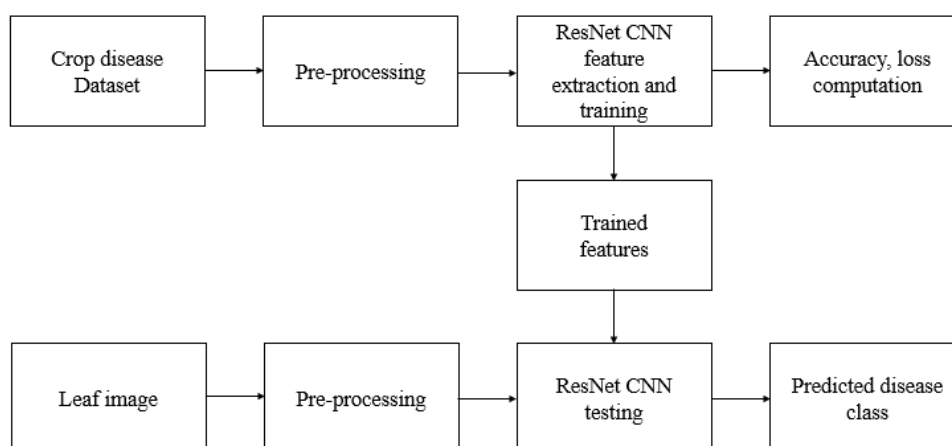

Fig.1: Block diagram of proposed system.

3.2 Image pre-processing

Digital image processing is the use of computer algorithms to perform image processing on digital images. As a subfield of digital signal processing, digital image processing has many advantages over analogue image processing. It allows a much wider range of algorithms to be applied to the input data — the aim of digital image processing is to improve the image data (features) by suppressing unwanted distortions and/or enhancement of some important image features so that our AI-Computer Vision models can benefit from this improved data to work on.

To train a network and make predictions on new data, your images must match the input size of the network. If you need to adjust the size of your images to match the network, then you can rescale or crop your data to the required size.

You can effectively increase the amount of training data by applying randomized augmentation to your data. Augmentation also enables you to train networks to be invariant to distortions in image data. For example, you can add randomized rotations to input images so that a network is invariant to the presence of rotation in input images. An augmented Image Datastore provides a convenient way to apply a limited set of augmentations to 2-D images for classification problems.

You can store image data as a numeric array, an ImageDatastore object, or a table. An ImageDatastore enables you to import data in batches from image collections that are too large to fit in memory. You can use an augmented image datastore or a resized 4-D array for training, prediction, and classification. You can use a resized 3-D array for prediction and classification only.

There are two ways to resize image data to match the input size of a network.

Rescaling multiplies the height and width of the image by a scaling factor. If the scaling factor is not identical in the vertical and horizontal directions, then rescaling changes the spatial extents of the pixels and the aspect ratio.

Cropping extracts a subregion of the image and preserves the spatial extent of each pixel. You can crop images from the center or from random positions in the image.

An image is nothing more than a two-dimensional array of numbers (or pixels) ranging between 0 and 255. It is defined by the mathematical function $f(x,y)$ where x and y are the two co-ordinates horizontally and vertically.

Resize image: In this step-in order to visualize the change, we are going to create two functions to display the images the first being a one to display one image and the second for two images. After that, we then create a function called processing that just receives the images as a parameter.

Need of resize image during the pre-processing phase, some images captured by a camera and fed to our AI algorithm vary in size, therefore, we should establish a base size for all images fed into our AI algorithms.

3.3 Convolutional Neural Networks

Deep neural network is gradually applied to the identification of crop diseases and insect pests. Deep neural network is designed by imitating the structure of biological neural

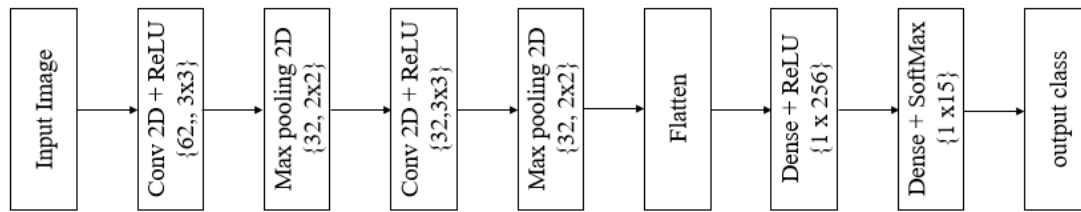

Fig. 2: A typical convolution neural network.

Table.1: Layers description.

Layer Names	No. of filters	Kernel size
Conv 2D +ReLU	32	3 x 3
Max pooling 2D	-	3 x 3
Conv 2D+ReLU	32	3 x 3
Max pooling 2D	-	3 x 3
Flatten	-	-
Dense +ReLU		1 x 256
Dense + SoftMax		1 x 15

network, an artificial neural network to imitate the brain, using learnable parameters to replace the links between neurons [3]. Convolutional neural network is one of the most widely used deep neural network structures, which is a branch of feed forward neural network [4]. The appearance of the deeper AlexNet network [11] in 2012 is the beginning of the modern convolutional neural network. The success of AlexNet network model also confirms the importance of convolutional neural network model. Since then, convolutional neural networks have developed vigorously and have been widely used in financial supervision, text and speech recognition, smart home, medical diagnosis, and other fields.

Convolutional neural networks are generally composed of three parts. Convolution layer for feature extraction. The convergence layer, also known as the pooling layer, is mainly used for feature selection. The number of parameters is reduced by reducing the number of features. The full connection layer carries out the summary and output of the characteristics. A convolution layer is consisting of a convolution process and a nonlinear activation function ReLU [12]. A typical architecture of CNN model for pattern recognition is shown in Fig. 1.

The leftmost image is the input layer, which the computer understands as the input of several matrices. Next is the convolution layer, the activation function of which uses ReLU. The pooling layer has no activation function. The combination of convolution and pooling layers can be constructed many times. The combination of convolution layer and convolution layer or convolution layer and pool layer can be very flexibly, which is not limited when constructing the model. But the most common CNN is a combination of several convolution layers and pooling layers. Finally, there

is a full connection layer, which acts as a classifier and maps the learned feature representation to the sample label space.

Convolutional neural network mainly solves the following two problems.

1) Problem of too many parameters: It is assumed that the size of the input picture is $50 * 50 * 3$. If placed in a fully connected feedforward network, there are 7500 mutually independent links to the hidden layer. And each link also corresponds to its unique weight parameter. With the increase of the number of layers, the size of the parameters also increases significantly. On the one hand, it will easily lead to the occurrence of over-fitting phenomenon. On the other hand, the neural network is too complex, which will seriously affect the training efficiency. In convolutional neural networks, the parameter sharing mechanism makes the same parameters used in multiple functions of a model, and each element of the convolutional kernel will act on a specific position of each local input. The neural network only needs to learn a set of parameters and does not need to optimize learning for each parameter of each position.

2) Image stability: Image stability is the local invariant feature, which means that the natural image will not be affected by the scaling, translation, and rotation of the image size. Because in deep learning, data enhancement is generally needed to improve performance, and fully connected feedforward neural is difficult to ensure the local invariance of the image. This problem can be solved by convolution operation in convolutional neural network.

3.4 DL-CNN

According to the facts, training and testing of DL-CNN involves in allowing every source image via a succession of convolution layers by a kernel or filter, rectified linear unit (ReLU), max pooling, fully connected layer and utilize SoftMax layer with classification layer to categorize the objects with probabilistic values ranging from $[0,1]$. Figure 1 discloses the architecture of DL-CNN that is utilized in proposed methodology for CBIR system for enhanced feature representation of word image over conventional retrieval systems.

It's a mathematical function which considers two inputs like source image $I(x, y, d)$ where x and y denotes the spatial coordinates i.e., number of rows and columns. d is denoted as dimension of an image (here $d = 3$, since the source image is RGB) and a filter or kernel with similar size of input image and can be denoted as $F(k_x, k_y, d)$.

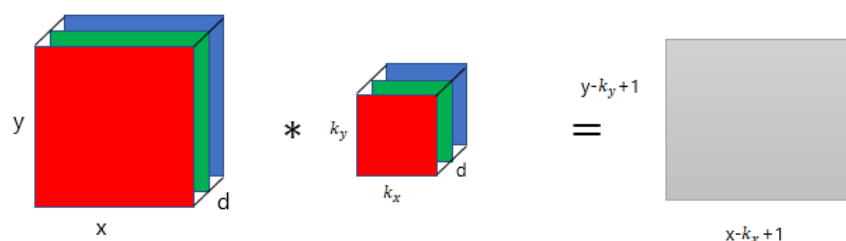
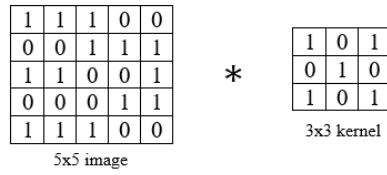
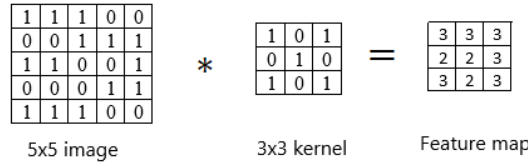

Fig. 3: Representation of convolution layer process.

The output obtained from convolution process of input image and filter has a size of $C((x - k_x + 1), (y - k_y + 1), 1)$, which is referred as feature map.



(a)



(b)

Fig. 4: Example of convolution layer process (a) an image with size 5×5 is convolving with 3×3 kernel (b) Convolved feature map

3.4.1 ReLU layer

Networks those utilizes the rectifier operation for the hidden layers are cited as rectified linear unit (ReLU). This ReLU function $\mathcal{G}(\cdot)$ is a simple computation that returns the value given as input directly if the value of input is greater than zero else returns zero. This can be represented as mathematically using the function $\max(\cdot)$ over the set of 0 and the input x as follows:

$$\mathcal{G}(x) = \max\{0, x\}$$

3.4.2 Max pooling layer

This layer mitigates the number of parameters when there are larger size images. This can be called as subsampling or down sampling that mitigates the dimensionality of every feature map by preserving the important information. Max pooling considers the maximum element form the rectified feature map.

3.5 Softmax classifier

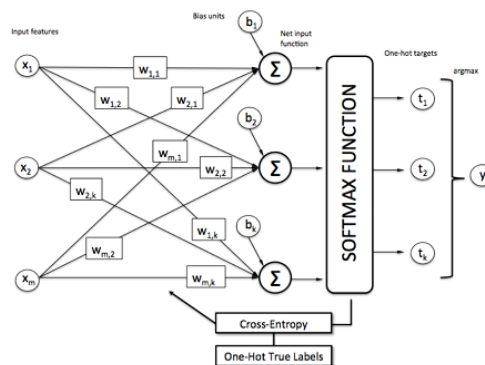

Fig. 5: Softmax classifier.

Generally, as seen in the above picture softmax function is added at the end of the output since it is the place where the nodes are meet finally and thus, they can be classified.

Here, X is the input of all the models and the layers between X and Y are the hidden layers and the data is passed from X to all the layers and Received by Y. Suppose, we have 10 classes, and we predict for which class the given input belongs to. So, for this what we do is allot each class with a particular predicted output. Which means that we have 10 outputs corresponding to 10 different class and predict the class by the highest probability it has.

4. RESULTS

This section gives the detailed analysis of simulation results implemented using “python environment”. Further, the performance of proposed method is compared with existing methods using same dataset.



Fig.6: Sample dataset.



Fig.7: Crop recognize as Pepper bell healthy.



Fig.8: Crop recognize as Pepper bell bacterial spot.

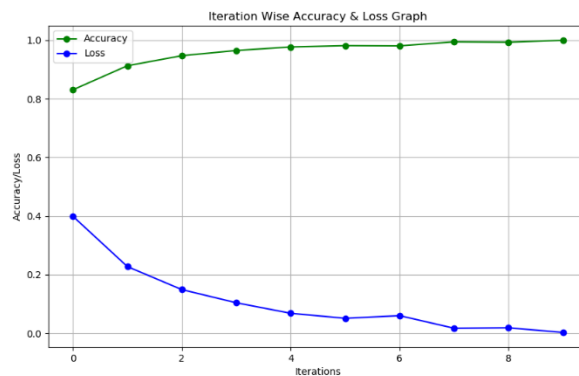

Fig.9: Iteration wise accuracy & loss graph.

5. CONCLUSION

In this paper 15 kinds of crops were studied. The model is constructed by using deep learning theory and convolution neural network technology. Experiments show that the model can effectively identify the data set, and the overall recognition accuracy is as high as 86.1%. The results show that the recognition accuracy of this hybrid network model is relatively higher than the traditional model, and it can be effectively applied to the identification and detection of plant diseases and insect pests.

In the future work, there are two directions should be improved:

1) Extended data set. In this paper, only 27 diseases of 10 crop species were studied, and other species and diseases were not involved, such as rice and wheat, and their related diseases. Therefore, the next step is to obtain more crop species and disease images for research.

2) Optimize the model. Through the experiment of this paper, we can see that Inception-resnet-v2 this kind of mixed network has absorbed the corresponding advantage. This model has achieved good recognition accuracy and is worthy of further study and optimization. At the same time, we should design a network model which can classify crop images with higher accuracy.

REFERENCES

- [1] A. H. B Abdul Wahab, R. Zahari and T. H. Lim, "Detecting diseases in Chilli Plants Using K-Means Segmented Support Vector Machine," 2019 3rd International Conference on Imaging, Signal Processing and Communication (ICISPC), 2019, pp. 57-61, doi: 10.1109/ICISPC.2019.8935722.
- [2] J. Francis, Anto Sahaya Dhas D and Anoop B K, "Identification of leaf diseases in pepper plants using soft computing techniques," 2016 Conference on Emerging Devices and Smart Systems (ICEDSS), 2016, pp. 168-173, doi: 10.1109/ICEDSS.2016.7587787.
- [3] M. Karuna, B. S Varsha, Sneha. R. M, G. K. Meghana. "Early Detection of Chili Plant Leaf Diseases using Machine Learning", IJESC, vol 9, issue no.5, 2019.
- [4] J. Schmidhuber, "Deep learning in neural networks: An overview," Neural Netw., vol. 61, pp. 85-117, Jan. 2015.
- [5] N. Srivastav, G. Chopra, P. Jain, and B. Khatter, "Pest Monitor and control system using WSN with special referance to acoustic device," in Proc. 27th ICEEE, Jan. 2013, pp. 92-99.
- [6] G. Athanikar and M. P. Badar, "Potato leaf diseases detection and classification system," Int. J. Comput. Sci. Mobile Comput., vol. 5, no. 2, pp. 76-88, 2016.

- [7] H. Wang, G. Li, Z. Ma, and X. Li, "Application of neural networks to image recognition of plant diseases," in Proc. Int. Conf. Syst. Informat. (ICSAI), May 2012, pp. 2159–2164.
- [8] D. Samanta, P. P. Chaudhury, and A. Ghosh, "Scab diseases detection of potato using image processing," *Int. J. Comput. Trends Technol.*, vol. 3, no. 1, pp. 109–113, 2012.
- [9] A. Krizhevsky, I. Sutskever, and G. E. Hinton, "ImageNet classification with deep convolutional neural networks," in Proc. Int. Conf. Neural Inf. Process. Syst. Red Hook, NY, USA: Curran Associates, 2012, pp. 1097–1105.
- [10] K. He, X. Zhang, S. Ren, and J. Sun, "Deep residual learning for image recognition," in Proc. IEEE Conf. Comput. Vis. Pattern Recognit., Jun. 2016, pp. 770–778.
- [11] E. C. Too, L. Yujian, S. Njuki, and L. Yingchun, "A comparative study of fine-tuning deep learning models for plant disease identification," *Comput. Electron. Agricult.*, vol. 161, pp. 272–279, Jun. 2019.
- [12] S. P. Mohanty, D. P. Hughes, and M. Salathé, "Using deep learning for image-based plant disease detection," *Frontiers Plant Sci.*, vol. 7, p. 1419, Sep. 2016.
- [13] S. Sladojevic, M. Arsenovic, A. Anderla, D. Culibrk, and D. Stefanovic, "Deep neural networks-based recognition of plant diseases by leaf image classification," in Proc. Comput. Intell. Neurosci., May 2016, Art. no. 3289801.
- [14] M. Dyrmann, H. Karstoft, and H. S. Midtiby, "Plant species classification using deep convolutional neural network," *Biosystems Eng.*, vol. 151, pp. 72–80, Nov. 2016.
- [15] I. Sa, Z. Ge, F. Dayoub, B. Upcroft, T. Perez, and C. McCool, "DeepFruits: A fruit detection system using deep neural networks," *Sensors*, vol. 16, no. 8, p. 1222, Aug. 2016.