

## PARKINSON'S DISEASE DETECTION BASED ON ANALYSIS OF SPEECH USING DEEP LEARNING

Smita Khond<sup>1</sup>, V. Poojitha<sup>2</sup>, P. Srisuja<sup>2</sup>, P. Laya<sup>2</sup>, P. Nithisha<sup>2</sup>

<sup>1,2</sup>Department of Information Technology

<sup>1,2</sup>Malla Reddy Engineering College for Women (A), Maisammaguda, Medchal, Telangana.

### ABSTRACT

Parkinson's disease (PD) is a progressive neurodegenerative disorder characterised histologically by the death of dopaminergic neurons in the substantia nigra pars compacta (SNpc) and the presence of Lewy bodies in various parts of the brain. The SNpc is a compact structure in the midbrain that plays a vital role in motor coordination and movement control by producing a chemical substance called dopamine, which is integral for controlling the initiation, velocity, and fluidity of voluntary movement sequences. The causes of most cases of PD (known as 'sporadic' or 'idiopathic' PD) are still unknown but involve complex interactions between genetic and environmental factors. PD is the second most common neurodegenerative disorder after Alzheimer's disease, affecting 1% of the population over the age of 60 and reaching approximately 5% at 85. The prevalence is rising due to ageing populations.

According to the Parkinson Disease Foundation, about 10 million people worldwide have PD, one million of them in the USA, 1.2 million in Europe, and two million projected in China by 2030. One out of 500 individuals in the UK are affected, and it is expected that this number will rise threefold in the next 50 years. There is currently no proven disease-modifying therapy. The diagnosis of PD requires the presence of bradykinesia (slowness of movements) in addition to muscle rigidity or tremor or postural instability. Approximately 20% of patients do not develop a tremor. The manifestations of PD are not limited to motor impairments.

Prompt diagnosis of PD is important in order to provide patients with appropriate treatment and information on prognosis. However, an accurate early diagnosis can be challenging because the movement symptoms can overlap with other conditions. Doctors make the diagnosis of PD based on clinical evaluation, interpreting information gained predominantly through history-taking and examination of the patient. Sometimes brain imaging may be requested to help support the clinical diagnosis, but there are currently no tests that are wholly sensitive or specific for Parkinson's. The rate of misdiagnosis of PD is approximately 10–25%, and the average time required to achieve 90% accuracy is 2.9 years. Autopsy is still the gold standard for the confirmation of the disease.

Therefore, this project designed an advanced convolution neural network model to predict Parkinson disease from both image and voice data. In general, existing ML algorithms such as SVM, and Random Forest will not filter data multiple times so its prediction accuracy is less hence CNN is used in this project, which filter data multiple times using neuron values so its prediction accuracy can be better. This project uses WAVE and SINE images of normal and Parkinson disease patients for imaging data and UCI Parkinson recorded voice is used for voice samples.

**Keywords:** Parkinson disease, CNN, voice and image samples.

### 1. INTRODUCTION

Parkinson's disease (PD) manifests as the death of dopaminergic neurons in the substantia nigra pars compacta within the midbrain. This neurodegeneration leads to a range of symptoms including coordination issues, bradykinesia, vocal changes, and rigidity. Dysarthria is also observed in PD patients; it is characterized by weakness, paralysis, and lack of coordination in the motor-speech

system: affecting respiration, phonation, articulation, and prosody. Since symptoms and the disease course vary, PD is often not diagnosed for many years. Therefore, there is a need for more sensitive diagnostic tools for PD detection because, as the disease progresses, more symptoms arise that make PD harder to treat. The main deficits of PD speech are loss of intensity, monotony of pitch and loudness, reduced stress, inappropriate silences, short rushes of speech, variable rate, imprecise consonant articulation, and harsh and breathy voice (dysphonia). The range of voice related symptoms is promising for a potential detection tool because recording voice data is non-invasive and can be done easily with mobile devices.

PD is one of the most chronic neurodegenerative diseases in today's world as it effects of the -year-old. PD is a prototypical movement disorder, and primary symptoms of PD are tremor, rigidity or muscle stiffness, bradykinesia and postural instability and these symptoms are generally known as Parkinsonism Syndrome. Parkinson's disease (PD) is a chronic neurodegenerative disease of that predominantly affects the elderly in today's world. For the diagnosis of the early stages of PD, effective and powerful automated techniques are needed by recent enabling technologies as a tool. Deep learning (DL) algorithms based on various diagnostic methodologies have been developed to detect PD and resolve related diagnostic issues. This research study offers a complete assessment of published surveys and DL-based diagnosis methodologies for PD recognition. The techniques of DL-based diagnostic approaches for PD recognition, such as PD dataset pre-processing, extraction and selection of features, and classification, are all included in this survey.

In recent years, there has been a significant increase in the use of machine learning based computer-aided diagnosis (CAD) systems to diagnose diseases, sometimes even in early stages. There has also been an increase in utilization of such CAD systems for diagnosing PD from various modalities like speech signals, gait signals, magnetic resonance imaging (MRI), positron emission tomography (PET), single-photon emission computed tomography (SPECT), Dopamine Transporter Scan (DaT Scan), tremor signal, handwriting signal, handwritten images, and various other clinical features (CF).

## **2. LITERATURE SURVEY**

Haq et al. discussed the various datasets used to evaluate the suggested PD recognition algorithms to better understand these datasets. The model evaluation metrics and cross-validation techniques used by different studies in this domain have also been explored in this survey. Considering the evaluated literature, this work also examined hot upcoming research issues and related solutions. Finally, this work came up with several trends and areas for future study that will aid progress in automatic disease recognition, particularly in detecting Parkinson's disease and its implementation in E-healthcare systems.

Clayton et al. introduced convolutional neural networks to learn features from images produced by handwritten dynamics, which capture different information during the individual's assessment. Additionally, this work makes available a dataset composed of images and signal-based data to foster the research related to computer-aided PD diagnosis. The analysis of handwritten dynamics using deep learning techniques showed to be useful for automatic Parkinson's disease identification, as well as it can outperform handcrafted features.

Tanveer et al. presented a comprehensive review of papers from 2013 to 2021 on the diagnosis of PD and its subtypes using artificial neural networks (ANNs) and deep neural networks (DNNs). This work presented detailed information and analysis regarding the usage of various modalities, datasets, architectures, and experimental configurations in a succinct manner. This work also presented an in-depth comparative analysis of various proposed architectures. Finally, presented several relevant future directions for researchers in this area.

Dash et al. implemented machine learning (ML) methods to address these difficulties and to refine the diagnosis and assessment procedures of PD, for the classification of PD and healthy controls or patients with similar clinical presentations. ML is a subfield of artificial intelligence (AI) that is increasingly applied to several medical diagnosis tasks, including to diagnose a wide range of diseases. This chapter provided an overview of the application of ML techniques and introduces some key concepts for PD diagnosis.

Nilashi et al. used Incremental support vector machine to predict Total-UPDRS and Motor-UPDRS. This work also used Non-linear iterative partial least squares for data dimensionality reduction and self-organizing map for clustering task. To evaluate the method, this work conducted several experiments with a PD dataset and present the results in comparison with the methods developed in the previous research. The prediction accuracies of method measured by MAE for the Total-UPDRS and Motor-UPDRS were obtained respectively MAE=0.4656 and MAE=0.4967.

Vilda et al. proposed methodology availed that the use of highly normalized descriptors as the probability distribution of kinematic variables of vowel articulation stability, which has some interesting properties in terms of information theory, boosts the potential of simple yet powerful classifiers in producing quite acceptable detection results in Parkinson Disease.

Maachi et al. proposed a novel intelligent Parkinson detection system based on deep learning techniques to analyze gait information. This work used 1D convolutional neural network (1D-Convnet) to build a Deep Neural Network (DNN) classifier. The proposed model processes 18 1D-signals coming from foot sensors measuring the vertical ground reaction force (VGRF). The first part of the network consists of 18 parallel 1D-Convnet corresponding to system inputs. The second part is a fully connected network that connects the concatenated outputs of the 1D-Convnets to obtain a final classification. This work tested the algorithm in Parkinson's detection and in the prediction of the severity of the disease with the Unified Parkinson's Disease Rating Scale (UPDRS).

Shivangi et al. introduced two neural network-based models namely, VGFR Spectrogram Detector and Voice Impairment Classifier, which aimed to help doctors and people in diagnosing disease at an early stage. An extensive empirical evaluation of CNNs (Convolutional Neural Networks) has been implemented on large-scale image classification of gait signals converted to spectrogram images and deep dense ANNs (Artificial Neural Networks) on the voice recordings, to predict the disease.

Pahuja et al. discussed three types of classifiers, namely, Multilayer Perceptron, Support Vector Machine and K-nearest neighbor on the benchmark (voice) dataset to compare and to know which of these classifiers is the most efficient and accurate for PD classification. The Voice input dataset for these classifiers has been obtained from UCI machine learning repository. ANN with Levenberg–Marquardt algorithm was found to be the best classifier, having highest classification accuracy (95.89%).

Lavalle et al. researched on Parkinson disease (PD) detection has shown that vocal disorders are linked to symptoms in 90% of the PD patients at early stages. Thus, there is an interest in applying vocal features to the computer-assisted diagnosis and remote monitoring of patients with PD at early stages. The contribution of this research is an increase of accuracy and a reduction of the number of selected vocal features in PD detection while using the newest and largest public dataset available. The best resulting accuracy is obtained by using a support vector machine and it is higher than the one, which was reported on the first work to use the same dataset. In addition, the corresponding computational complexity is further reduced by selecting no more than 20 features.

Zhang et al. investigated the mobile health (for short mHealth) technology for preventive medicine, particularly in chronic disease management. Notably, many types of research have explored the

possibility of using mobile and wearable personal devices to detect the symptom of PD and shown promising results. It provided opportunities for transforming early PD detection from clinical to daily life. This survey paper attempted to conduct a comprehensive review of mHealth technologies for PD detection from 2000 to 2019 and compared their pros and cons in practical applications and provides insights to close the performance gap between state-of-the-art clinical approaches and mHealth technologies.

Alzubaidi et al. aimed to explore and summarize the applications of neural networks to diagnose PD. PRISMA Extension for Scoping Reviews (PRISMA-ScR) was followed to conduct this scoping review. To identify the relevant studies, both medical databases (e.g., PubMed) and technical databases (IEEE) were searched. Three reviewers carried out the study selection and extracted the data from the included studies independently. Then, the narrative approach was adopted to synthesis the extracted data.

Ali et al. proposed to use random under sampling method to balance the training process. The second problem is low rate of classification accuracy which has limited clinical significance. To improve the PD detection accuracy, this work proposed a cascaded learning system that cascades a Chi2 model with adaptive boosting (Adaboost) model. The Chi2 model ranks and selects a subset of relevant features from the feature space while Adaboost model is used to predict PD based on the subset of features.

Wodzinski et al. presented an approach to Parkinson's disease detection using vowels with sustained phonation and a ResNet architecture dedicated originally to image classification. This work calculated spectrum of the audio recordings and used them as an image input to the ResNet architecture pre-trained using the ImageNet and SVD databases. To prevent overfitting the dataset was strongly augmented in the time domain. The Parkinson's dataset (from PC-GITA database) consists of 100 patients (50 were healthy / 50 were diagnosed with Parkinson's disease). Each patient was recorded 3 times. The obtained accuracy on the validation set is above 90% which is comparable to the current state-of-the-art methods.

Quan et al. explored static and dynamic speech features relating to PD detection. A comparative analysis of the articulation transition characteristics showed that the number of articulation transitions and the trend of the fundamental frequency curve are significantly different between HC speakers and PD patients. Motivated by this observation, this work proposed to apply Bidirectional long-short term memory (LSTM) model to capture time-series dynamic features of a speech signal for detecting PD. The dynamic speech features are measured based on computing the energy content in the transition from unvoiced to voiced segments (onset), and in the transition from voiced to unvoiced segments (offset).

### **3. PROPOSED SYSTEM**

In this project we are designing Advanced Convolution Neural Network based Machine Learning algorithm model to predict Parkinson disease from both Image and voice data. All existing ML algorithms such as SVM, Random Forest will not filter data multiple times so its prediction accuracy is less so we have used CNN algorithm which filter data multiple times using NEURON values so its prediction accuracy can be better.

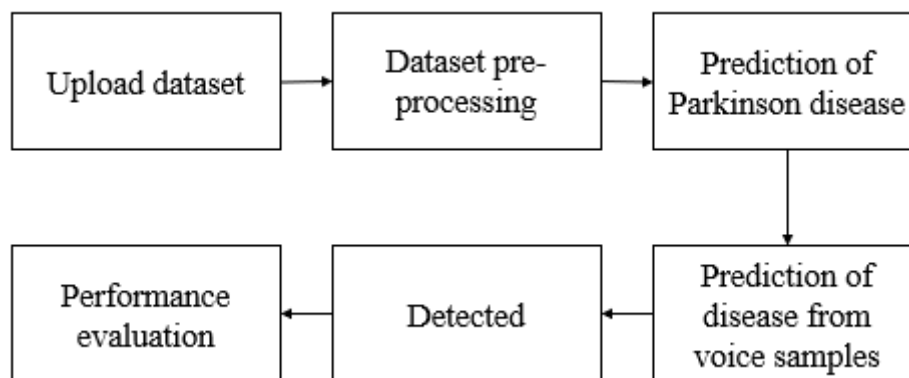

Fig. 1: Block diagram of proposed system.

### 3.1 Pre-processing

Data pre-processing is a process of preparing the raw data and making it suitable for a machine learning model. It is the first and crucial step while creating a machine learning model.

When creating a project, it is not always a case that we come across the clean and formatted data. And while doing any operation with data, it is mandatory to clean it and put in a formatted way. So, for this, we use data pre-processing task.

#### *Why do we need Data Pre-processing?*

A real-world data generally contains noises, missing values, and maybe in an unusable format which cannot be directly used for machine learning models. Data pre-processing is required tasks for cleaning the data and making it suitable for a machine learning model which also increases the accuracy and efficiency of a machine learning model.

- Getting the dataset
- Importing libraries
- Importing datasets
- Finding Missing Data
- Encoding Categorical Data
- Splitting dataset into training and test set
- Feature scaling

#### 3.1.1 Splitting the Dataset into the Training set and Test set

In machine learning data pre-processing, we divide our dataset into a training set and test set. This is one of the crucial steps of data pre-processing as by doing this, we can enhance the performance of our machine learning model.

Suppose if we have given training to our machine learning model by a dataset and we test it by a completely different dataset. Then, it will create difficulties for our model to understand the correlations between the models.

If we train our model very well and its training accuracy is also very high, but we provide a new dataset to it, then it will decrease the performance. So we always try to make a machine learning model which performs well with the training set and also with the test dataset. Here, we can define these datasets as:

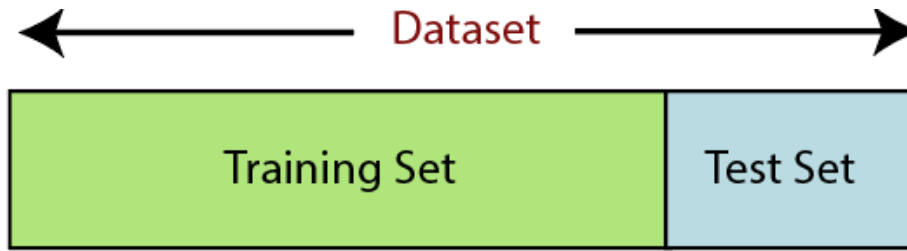

**Training Set:** A subset of dataset to train the machine learning model, and we already know the output.

**Test set:** A subset of dataset to test the machine learning model, and by using the test set, model predicts the output.

**3.2 DL-CNN**

According to the facts, training and testing of CNN involves in allowing every source data via a succession of convolution layers by a kernel or filter, rectified linear unit (ReLU), max pooling, fully connected layer and utilize SoftMax layer with classification layer to categorize the objects with probabilistic values ranging from.

Convolution layer is the primary layer to extract the features from a source image and maintains the relationship between pixels by learning the features of image by employing tiny blocks of source data. It's a mathematical function which considers two inputs like source image  $I(x, y, d)$  where  $x$  and  $y$  denotes the spatial coordinates i.e., number of rows and columns.  $d$  is denoted as dimension of an image (here  $d=3$  since the source image is RGB) and a filter or kernel with similar size of input image and can be denoted as  $F(k_x, k_y, d)$ .

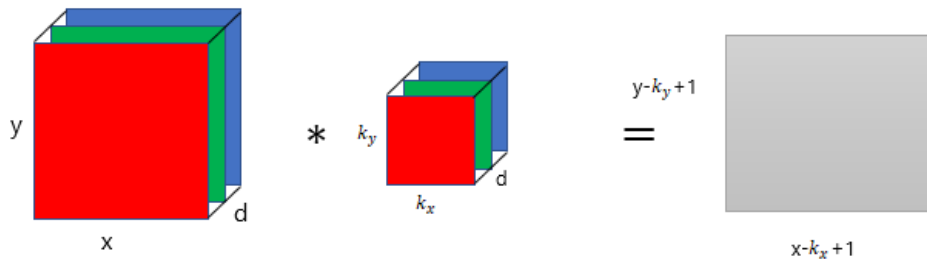
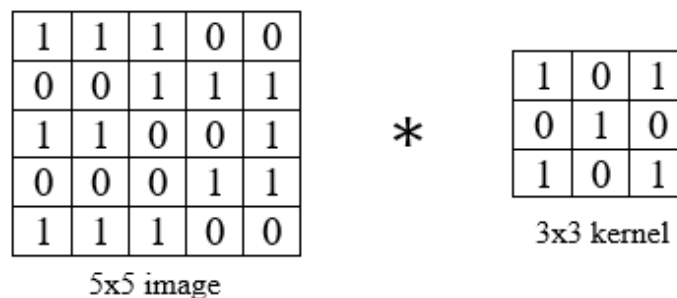

Fig. 2: Representation of convolution layer process.

The output obtained from convolution process of input image and filter has a size of  $C((x - k_x + 1), (y - k_y + 1), 1)$ , which is referred as feature map. Let us assume an input image with a size of  $5 \times 5$  and the filter having the size of  $3 \times 3$ . The feature map of input image is obtained by multiplying the input image values with the filter values.



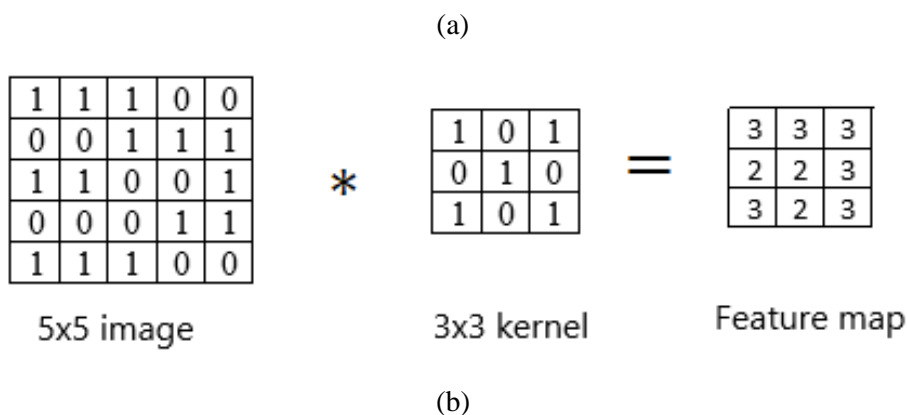

Fig. 3: Example of convolution layer process (a) an image with size 5x5 is convolving with 3x3 kernel (b) Convolved feature map.

**ReLU layer**

Networks those utilizes the rectifier operation for the hidden layers are cited as rectified linear unit (ReLU). This ReLU function  $\mathcal{G}(\cdot)$  is a simple computation that returns the value given as input directly if the value of input is greater than zero else returns zero. This can be represented as mathematically using the function  $\max(\cdot)$  over the set of 0 and the input x as follows:

$$\mathcal{G}(x) = \max\{0, x\}$$

**Max pooling layer**

This layer mitigates the number of parameters when there are larger size images. This can be called as subsampling or down sampling that mitigates the dimensionality of every feature map by preserving the important information. Max pooling considers the maximum element form the rectified feature map.

**Advantages of proposed system**

- CNNs do not require human supervision for the task of identifying important features.
- They are very accurate at image recognition and classification.
- Weight sharing is another major advantage of CNNs.
- Convolutional neural networks also minimize computation in comparison with a regular neural network.
- CNNs make use of the same knowledge across all image locations.

**4. RESULTS AND DISCUSSION**

To train CNN we have used WAVE and SINE images of normal and Parkinson disease patients and for voice we have used UCI Parkinson recorded voice and this dataset can be downloaded from below URL.

<https://archive.ics.uci.edu/ml/machine-learning-databases/00489/>

Below screen showing images used in this project to train CNN model



In above screen we have both wave and sine images and in below screen we can see voice data samples taken from different patients.

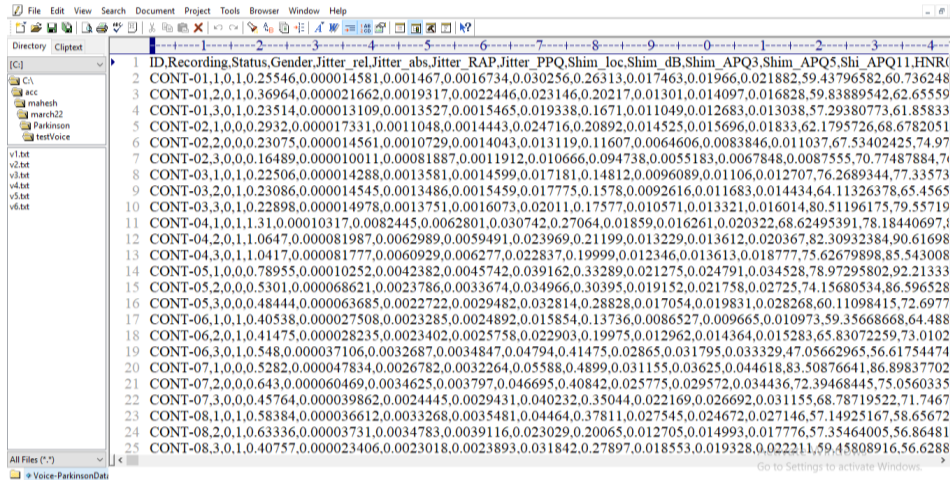

In above screen first row contains dataset column names and remaining are the dataset values. We trained CNN by using above datasets.

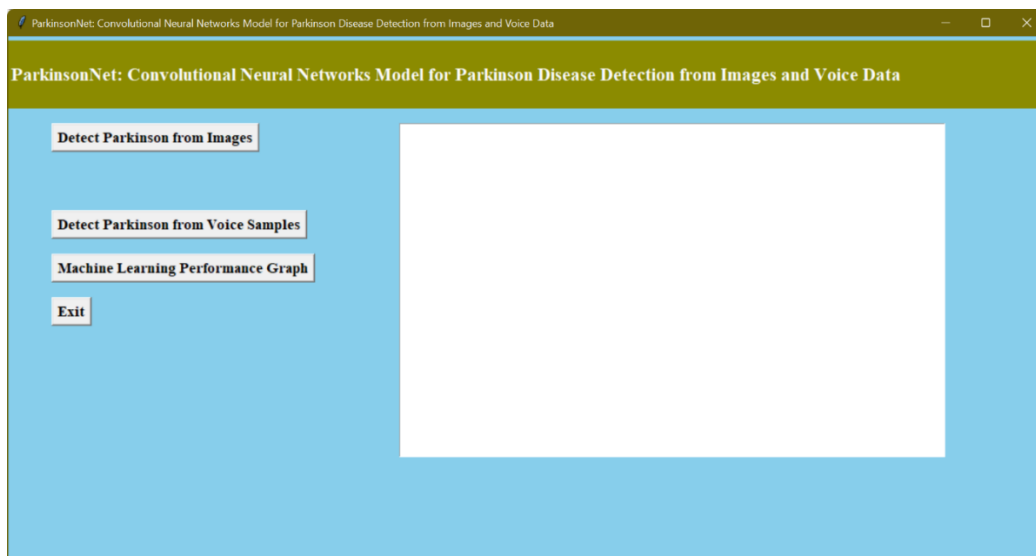

In above screen click on 'Detect Parkinson from Images' button to upload images and to get below screen



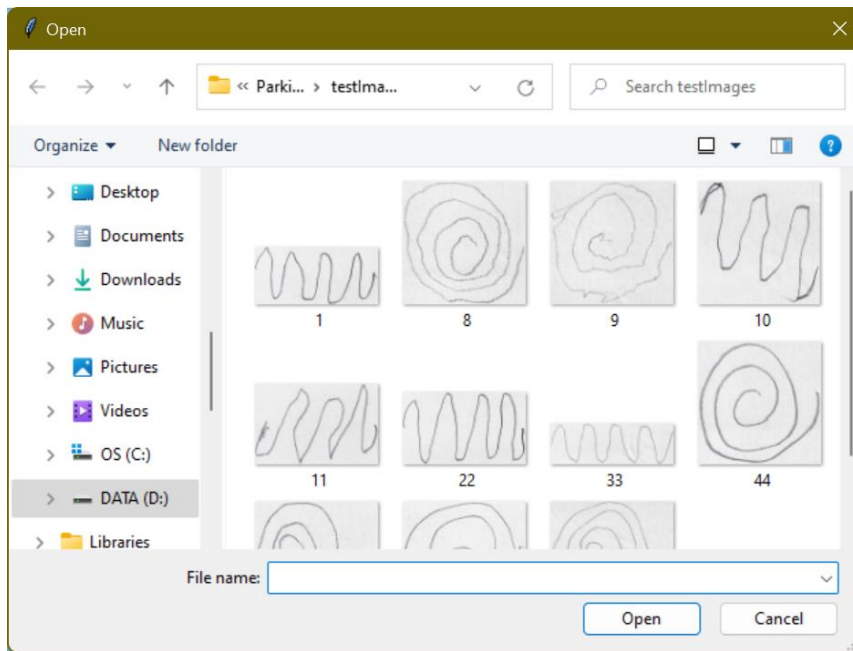

In above screen selecting and uploading '8.png' file and then click on 'Open' button to get below output



In above screen image is predicted as 'Parkinson' disease and now test other images. For selected image of 44.png, we will get below output



Above image is predicted as HEALTHY and similarly you can upload and test other image and now click on 'Detect Parkinson from Voice Samples' button to upload voice data and get below output

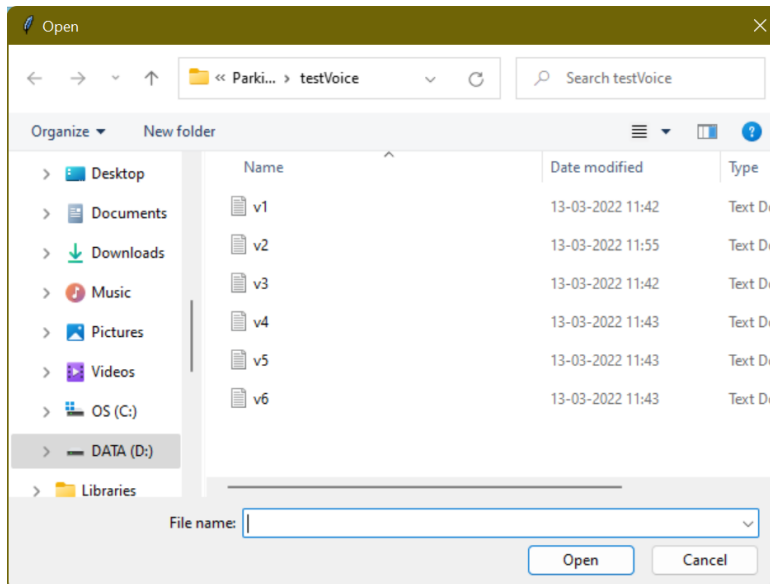

In above screen selecting and uploading 'v1.txt' voice data and then click on 'Open' button to get below output

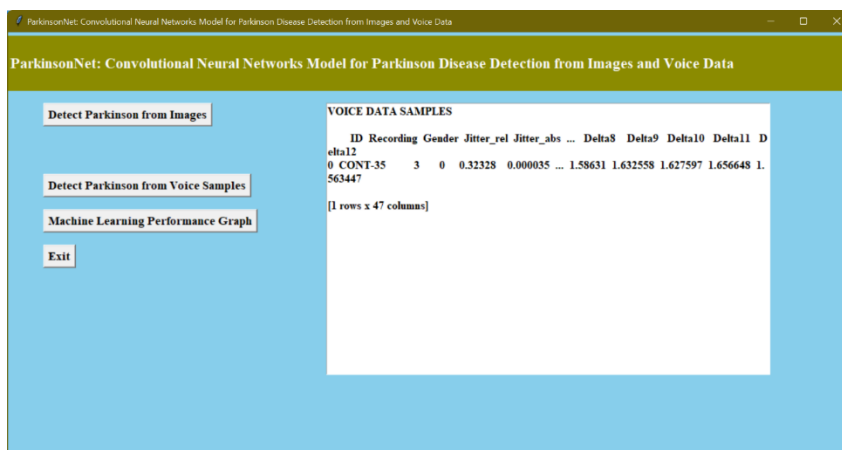

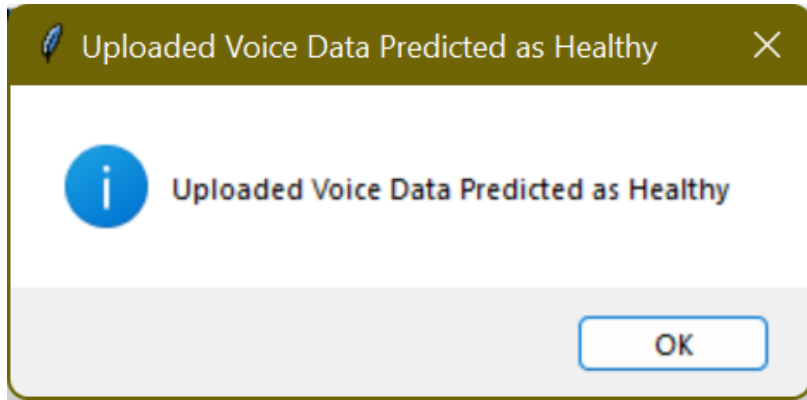

In above screen in text area, we can see the voice recording data and in dialog box we can see voice data predicted as “HEALTHY” and now test other voice

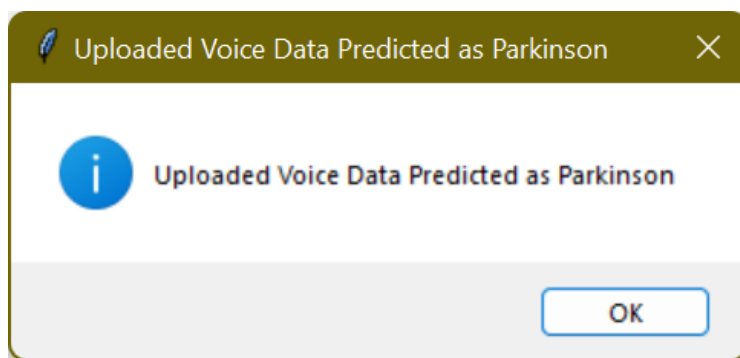
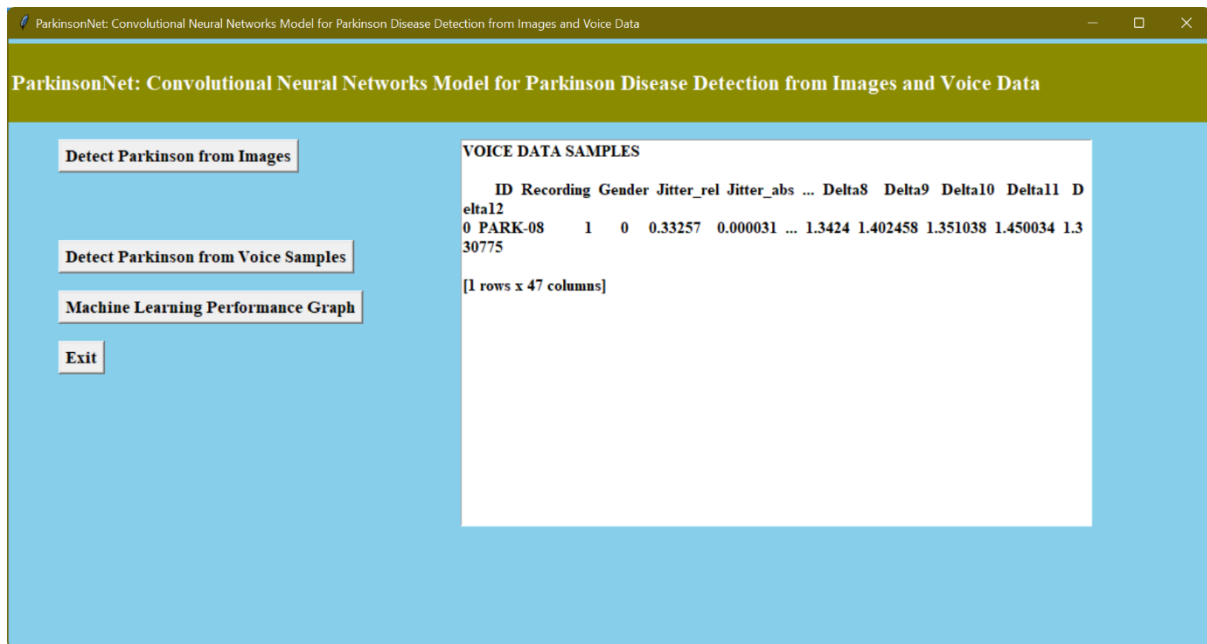

In above screen voice data predicted as ‘Parkinson’ disease and similarly you can upload and test other images. Now click on ‘Machine Learning Performance Graph’ button to get accuracy and loss graph of bot images and Voice CNN algorithm

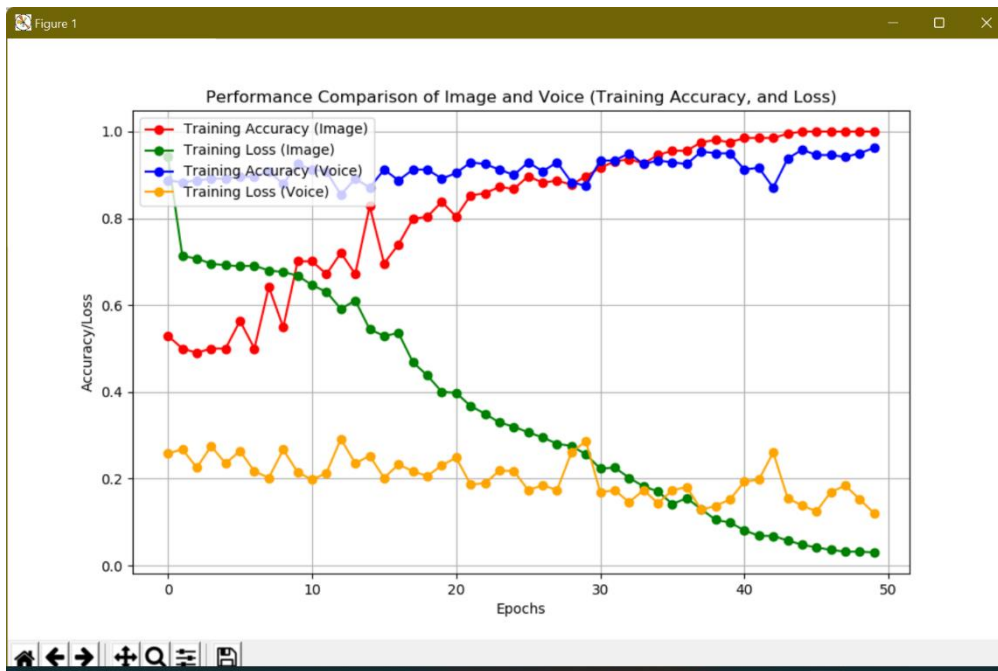

In above graph x-axis represents training epoch and y-axis represents accuracy and loss values and in above graph we can see with each increasing epoch accuracy got increase and loss got decrease and we can see at final epoch accuracy reached closer to 1 and loss reached closer to 0. In above graph blue line is for voice accuracy and red line is for image accuracy and green line for image loss and yellow line for voice loss.

## 5. CONCLUSION AND FUTURE WORK

The early detection of PD is essential to a better understanding of the disease causes, initiate therapeutic interventions, and enable developing appropriate treatments. This project proposed a deep CNN model to automatically discriminate normal individuals and patients affected by PD. The proposed ParkinsonNet model showed good detection capacity by reaching good accuracy. This is mainly due to the desirable characteristics of the machine learning model in learning linear and nonlinear features from PD data without the need for hand-crafted features extraction. In the future, we are planning to study considered features and to adopt PD detection method for patients with PD at early stage.

## REFERENCES

- [1] U Haq, J. P. Li, B. L. Y. Agleby, C. B. Mawuli, Z. Ali, S. Nazir, S. U. Din, "A survey of deep learning techniques-based Parkinson's disease recognition methods employing clinical data", *Expert Systems with Applications*, Volume 208, 2022, 118045, ISSN 0957-4174, <https://doi.org/10.1016/j.eswa.2022.118045>.
- [2] Clayton R. Pereira, Danilo R. Pereira, Gustavo H. Rosa, Victor H.C. Albuquerque, Silke A.T. Weber, Christian Hook, João P. Papa, Handwritten dynamics assessment through convolutional neural networks: An application to Parkinson's disease identification, *Artificial Intelligence in Medicine*, Volume 87, 2018, Pages 67-77, ISSN 0933-3657, <https://doi.org/10.1016/j.artmed.2018.04.001>.
- [3] M. Tanveer, A.H. Rashid, Rahul Kumar, R. Balasubramanian, Parkinson's disease diagnosis using neural networks: Survey and comprehensive evaluation, *Information Processing & Management*, Volume 59, Issue 3, 2022, 102909, ISSN 0306-4573, <https://doi.org/10.1016/j.ipm.2022.102909>.

- [4] S. Dash, A systematic review of adaptive machine learning techniques for early detection of Parkinson's disease, *Artificial Intelligence for Neurological Disorders*, Academic Press, 2023, Pages 361-385, ISBN 9780323902779, <https://doi.org/10.1016/B978-0-323-90277-9.00018-3>.
- [5] M. Nilashi, O. Ibrahim, H. Ahmadi, L. Shahmoradi, M. Farahmand, A hybrid intelligent system for the prediction of Parkinson's Disease progression using machine learning techniques, *Biocybernetics and Biomedical Engineering*, Volume 38, Issue 1, 2018, Pages 1-15, ISSN 0208-5216, <https://doi.org/10.1016/j.bbe.2017.09.002>.
- [6] Vilda, Pedro, et al. "Parkinson disease detection from speech articulation neuromechanics." *Frontiers in neuroinformatics* 11 (2017): 56.
- [7] I. E Maachi, G.A Bilodeau, W. Bouachir, Deep 1D-Convnet for accurate Parkinson disease detection and severity prediction from gait, *Expert Systems with Applications*, Volume 143, 2020, 113075, ISSN 0957-4174, <https://doi.org/10.1016/j.eswa.2019.113075>.
- [8] Shivangi, A. Johri and A. Tripathi, "Parkinson Disease Detection Using Deep Neural Networks," 2019 Twelfth International Conference on Contemporary Computing (IC3), 2019, pp. 1-4, doi: 10.1109/IC3.2019.8844941.
- [9] G. Pahuja & T. N. Nagabhushan (2021) A Comparative Study of Existing Machine Learning Approaches for Parkinson's Disease Detection, *IETE Journal of Research*, 67:1, 4-14, DOI: 10.1080/03772063.2018.1531730.
- [10] G. S. Lavalle, J. C. G. Hernández, R. R. Romero, Automatic Parkinson disease detection at early stages as a pre-diagnosis tool by using classifiers and a small set of vocal features, *Biocybernetics and Biomedical Engineering*, Volume 40, Issue 1, 2020, Pages 505-516, ISSN 0208-5216, <https://doi.org/10.1016/j.bbe.2020.01.003>.
- [11] H. Zhang, C. Song, A. S. Rathore, M. -C. Huang, Y. Zhang and W. Xu, "mHealth Technologies Towards Parkinson's Disease Detection and Monitoring in Daily Life: A Comprehensive Review," in *IEEE Reviews in Biomedical Engineering*, vol. 14, pp. 71-81, 2021, doi: 10.1109/RBME.2020.2991813.
- [12] Alzubaidi MS, Shah U, Dhia Zubaydi H, Dolaat K, Abd-Alrazaq AA, Ahmed A, Househ M. The Role of Neural Network for the Detection of Parkinson's Disease: A Scoping Review. *Healthcare*. 2021; 9(6):740. <https://doi.org/10.3390/healthcare9060740>.
- [13] L. Ali, C. Zhu, N. A. Golilarz, A. Javeed, M. Zhou and Y. Liu, "Reliable Parkinson's Disease Detection by Analyzing Handwritten Drawings: Construction of an Unbiased Cascaded Learning System Based on Feature Selection and Adaptive Boosting Model," in *IEEE Access*, vol. 7, pp. 116480-116489, 2019, doi: 10.1109/ACCESS.2019.2932037.
- [14] M. Wodzinski, A. Skalski, D. Hemmerling, J. R. Orozco-Arroyave and E. Nöth, "Deep Learning Approach to Parkinson's Disease Detection Using Voice Recordings and Convolutional Neural Network Dedicated to Image Classification," 2019 41st Annual International Conference of the IEEE Engineering in Medicine and Biology Society (EMBC), 2019, pp. 717-720, doi: 10.1109/EMBC.2019.8856972.
- [15] C. Quan, K. Ren and Z. Luo, "A Deep Learning Based Method for Parkinson's Disease Detection Using Dynamic Features of Speech," in *IEEE Access*, vol. 9, pp. 10239-10252, 2021, doi: 10.1109/ACCESS.2021.3051432.