

EARTHQUAKE DETECTOR USING ARDUINO

¹M.Krishna,²A.Vinitha,³S.Ravinder,⁴D.Swetha

¹²³⁴Assistant Professor

Department Of ECE

Kshatriya College of Engineering

ABSTRACT

Earthquake early warning efforts aim to detect earthquakes and provide seconds of warning for surrounding populations. Here a working module rapidly detecting and characterizing earthquakes with the Quake-Catcher Network (QCN), which connects low-cost Micro Electro Mechanical Systems (MEMS) accelerometers to a volunteer network of an embedded system is designed.

Large magnitude earthquakes may cause significant losses of life and property. The concept is to detect the vibrations or jerks in the Earth, raise the alarm and alert the people. This concept can be proved practically with MEMS accelerometer mechanism. A method is described in the present disclosure which includes detecting of a seismic movement by an accelerometer (MEMS).

This mechanism can be installed under the ground or over the concrete base and if there is any jerk in the ground, the sensor (MEMS) will be deviated from its position. Now this sensor depending on the deviation of the angle, it gives the voltage variation. The output voltage variation from the sensor is fed to the ADC pin of the Arduino for converting it into digital data. This digital information is read by the controller that checks with the predetermined threshold, and activates through the speaker as an acknowledgement to the surrounding people and simultaneously this information is also displayed in the LCD as well that is interfaced to the Arduino controller.

I. INTRODUCTION

1.1 PROJECT OVERVIEW

The main aim of the project is to provide alerts about earthquake before it comes by using the MEMS technology. The MEMS Sensors, having the X and Y coordinates which are used for sensing the movements in all directions, are used to find out the disturbance i.e., movement in all the directions. When the MEMS identify any of the movements, it gives information to a microcontroller. The microcontroller will automatically gives a warning message by activating the alarm as an acknowledgement and the information will also be displayed in the digital display (LCD).

Rapid detection and characterization of earthquakes can provide nearby populations with seconds of earthquake early warning (EEW) prior to strong shaking. Regional EEW systems have been proposed, tested, or implemented in relatively few regions, including California, Japan, Mexico, Taiwan, and Turkey. Rapid earthquake detection is primarily limited by the high costs of instrumentation and required infrastructure. Japan has the most developed EEW system, with over 1000 traditional seismic stations spaced at ~20 km intervals. The Japanese system recently issued a successful alert during the 11 March, 2011 Mw9 Tōhoku, Japan earthquake.

EEW systems rapidly determine the location and magnitude of an ongoing earthquake rupture. Earthquake locations are estimated from the arrival times of seismic waves propagating across a sensor network. While peak ground velocity (PGV) or acceleration (PGA) can be used to estimate earthquake magnitude, the scatter in PGV and PGA requires measurements from multiple stations to yield stable earthquake magnitude estimates. Thus earthquake magnitude estimates are often delayed by seconds to minutes in regions with fewer seismic sensors or slow data communications. Because most regions have sparse seismic networks, more sophisticated data analyses are required to obtain stable estimates with fewer measurements. For example, various algorithms analyze the period of the P-wave velocity or displacement, which provides an earthquake magnitude estimate. To use this method with accelerometer data, accelerograms must be integrated once or twice to velocity or displacement, which can be less reliable at higher-noise sites like those in urban areas. Here, we describe the real-time detection algorithm implemented for the Quake-Catcher Network. This algorithm monitors peak acceleration (as a three-component vector magnitude) between 0 and 4 seconds following the onset of new strong motions detected at each sensor-station.

New sensor technology and computational techniques provide an avenue for reducing the cost of building dense seismic networks and implementing EEW systems. Small and low-cost Micro Electro

Mechanical Systems (MEMS) triaxial sensors yield high quality records of ground acceleration.

1.2 MOTIVATION OF PROJECT

In the era of globalization, advances in science and technology are quite rapid. It is characterized by electronic devices used by the public is able to facilitate the work. According Brathwaithe cited by Fitri (2013: 2) states that in the study of physics, electronics and instrumentation has the potential to contribute to the development of science and technology is appropriate for the product results from the work of students who are useful to society, both in the industrial, scientific and field a common one with making tool to detect the existence of an earthquake.

Based on the above be the main driver for designing an earthquake warning and detection equipment using vibration sensors. By applying the concept of Embedded systems as its base, the tool is able to provide great benefits in the community. The working of the vibration sensor is a combination of mechanical and electronic circuit design. The design of the system that will be done is a design-oriented low cost simple design. Vibration sensor is a simple sensor that consists of a pendulum made of metal and slabs of a circle that serves as a catcher vibrations resulting from the earthquake and flow of electric current. Based on the descriptions exposed above, will be designed detectors and warning of earthquakes by using a vibration sensor.

1.3 BLOCK DIAGRAMABSTRACT

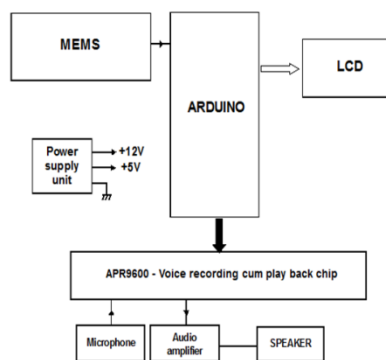

Fig 1.– Block diagram of Earthquake detector

In the block diagram of Earthquake detector, the main component is Arduino Uno. Input of the device is power supply and MEMS Sensor which takes receives the vibration of ground and the output is seen on LCD and warning is given through speaker. Therefore, the detection of earthquake is done.

1.4 EXPLANATION OF EACH BLOCK ARDUINO UNO

The Arduino UNO is a frequently used microcontroller board in the family of Arduino. This is the latest third version of an Arduino board and released in the year 2011. The main advantage of this board is if we make a mistake, we can change the microcontroller on the board. The main features of this board mainly include, it is available in DIP (Dual-inline-package), detachable and ATmega328p microcontroller. It is very easy to load the program in the microcontroller by using an Arduino computer program. This board has huge support from the Arduino community, which will make a very simple way to start working in embedded electronics, and many more applications.

MEMS SENSOR

MEMS is a class of systems that are physically small. These systems have both electrical and mechanical components. MEMS originally used modified integrated circuit (computer chip) fabrication techniques and materials to create these very small mechanical devices.

Micro Electro Mechanical System or MEMS represent an extraordinary technology that promises to transform whole industries and drive the next technological revolution. These devices can replace bulky actuators and sensors with micron scale equivalents that can be produced in large quantities by fabrication processes used in integrated circuit photolithography. This reduces cost, bulk, weight and power consumption while increasing performance, production volume, and functionality by orders of magnitude.

POWER SUPPLY

A power supply is an electrical device that supplies electric power to an electrical load. The primary function of a power supply is to convert electric current from a source to the correct voltage, current and frequency to power the load. As a result, power supplies are sometimes referred to as electric power converters. Some power supplies are separate standalone pieces of equipment, while others are built into load appliances that they power. Examples of the latter include power supplies found in desktop computers and consumer electronic devices.

LIQUID CRYSTAL DISPLAY (LCD)

The LCD is interfaced to the controller for displaying the earthquake severity conditions. LCD Displays are dominating LED displays, because these displays can display alphabets, numbers and some kind of special symbols, where as LED's (seven segment display) can display only numbers. These LCD displays are very useful for displaying user information and

communication. LCD displays are available in various formats. Most common are 2 x 16, is that two lines with 16 alphanumeric characters. Other formats are 3x16, 2x40, 3x40 etc.

In recent years LCD is finding widespread use replacing LED's, because of the ability to display numbers, characters, and graphics. Another advantage is, because of its compactness and ease of programming for characters and graphics, more information in the form of text message or graphics can be displayed. Generally, the LCD modules have an 8-bit interface, besides the 8-bit data bus; the interface has a few other control lines. The default data transfer between the LCD module and an external device is 8-bits, however it is possible to communicate with the LCD module using only four of the 8-data lines. The R/W line is connected to ground and hence the processor cannot read any status information from the LCD module, but can only write data to the LCD.

SPEAKER

The primary objective of speakers is to offer audio output for the listener. The electromagnetic waves are converted into sound waves through the speaker as they are transducers. The devices, like an audio receiver or computer, give audio input to speakers, which may be in the form of analog or digital. The function of the analog speaker is simply to magnify the analog electromagnetic waves into sound waves. Speakers are transducers that convert electromagnetic waves into sound waves. The speakers receive audio input from a device such as a computer or an audio receiver. This input may be either in analog or digital form. Analog speakers simply amplify the analog electromagnetic waves into sound waves. Since sound waves are produced in analog form, digital speakers must first convert the digital input to an analog signal, then generate the sound waves. The sound produced by speakers is defined by frequency and amplitude.

AUDIO AMPLIFIER

An audio power amplifier (or power amp) is an electronic amplifier that amplifies low-power electronic audio signals, such as the signal from a radio receiver or an electric guitar pickup, to a level that is high enough for driving loudspeakers or headphones. Audio power amplifiers are found in all manner of sound systems including sound reinforcement, public address, home audio systems and musical instrument amplifiers like guitar amplifiers. It is the final electronic stage in a typical audio playback chain before the signal is sent to the loudspeakers.

The preceding stages in such a chain are low-power audio amplifiers which perform tasks like pre-amplification of the signal, equalization, mixing different input signals. The inputs can also be any number of audio sources like record players, CD players, digital audio players and cassette players. Most audio power amplifiers require these low-level inputs, which are line level.

APR9600 – VOICE RECORDING CUM PLAYBACK CHIP

There are various types of voice processing chip (IC) with various features for speech compression and processing is readily available. Here is projects called Voice recording and play back using chip (APR9600). An APR9600 is a single chip voice recorder and playback device from Aplus integrated circuits. This chip used flash non volatile memory to store up to 256 voltage levels. i.e. for 32 to 60 seconds. This chip have many features like, one can select sample rates with consequent quality and recording times. Microphone amplifier, automatic gain control (AGC).

MICROPHONE

Microphones are an essential part of any audio recording system. The microphone picks up the sound and converts it into electrical energy that can then be processed by electronic amplifiers and audio processing systems.

Microphones come in all shapes and sizes. Also different types of microphone may use different technologies. These different types of microphone have different properties, and therefore a knowledge of the various forms of microphone will enable the best microphone type to be chosen for a given application.

In terms of their technology, most microphones use electromagnetic induction (dynamic microphones), capacitance change (condenser microphones) or piezoelectricity (crystal or ceramic microphone

II. LITERATURE SURVEY

2.1 INTRODUCTION

A literature survey is a proof essay of sorts. It is a study of relevant literature materials in relation to a topic we have been given. The problem with the fixed position antennas is the broadcasting signal strength may vary due to the climatic changes. Now-a-days due to the increased construction of skyscrapers, the strength of the broadcast signals received by the antenna are becoming weak. If an individual wants to adjust the position manually it becomes complex to adjust the whole system using man power. Our project will focus on reducing the man effort for positioning the antenna using microcontroller and remote. It works with Arduino. It

replaces the manual work with a simple switching to position the antenna for maximum gain of the broadcasting signal.

This project idea was introduced in the early 90's by P. K. Saha, S. S. Ahsan, M. H. Bhuyan, K. Islam and AHM Z. Alam in an International Conference on Computing and Information Technology, held at Dhaka, Bangladesh in the year 1998.

FRAMEWORK OF THINKING

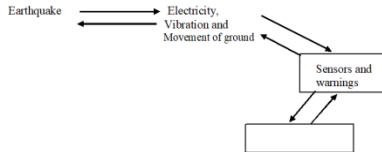

Fig 2. Framework of thinking

The earthquake is a natural event that occurred vibrations at the surface (skin) of the earth caused by the release of energy suddenly from the epicenter (endogenous force). Based on the cause of earthquakes are classified into:

1. Tectonism
2. Volcanism

Seisme Bayong (2013) states, according to the occurrence, earthquakes are classified into the following.

1. Preliminary Earthquake
2. The Main Quake
3. Aftershocks

Vibration is experienced alternating movement of an object towards a point of equilibrium. When the vibrations propagate, then it generates a wave. The influence of vibrations and waves affect the functioning of the detectors and the warning of this quake. When the earth shook, and the vibrations propagate in the Earth's plates, thus generating seismic waves, the resulting energy propagation propagate to all parts of the earth. The effect caused by the presence of such seismic waves, move or breakage tectonic plates, which we are familiar with the term earthquake. From the state of the Earth vibrating plate, the pendulum on an earthquake warning detectors and will move and vibrate. Pendulum vibration causes the pendulum touches the circle electrical copper wire connected, and the bell. So the sound of the bell sign earthquakes have been/is going. Inside the bell, there is also the concept of wave, in which electricity flows on the bell produces vibrations on the membrane inside the bell, which causes resonance at around membrane. Resonance around the membrane generates longitudinal waves. The result buzzer sounded loud to us.

III. TECHNICAL DESCRIPTION

3.1 DESCRIPTION

The Earthquake Detector using Arduino and MEMS sensor is built to reduce the loss of life and property in the earthquake prone areas. The system contains MEMS sensor which checks the movement of ground plates in X and Y axis. This sensor receives the vibration from the ground. The sensor is place on or above the ground to check the vibrations in the earth. The input data is transferred to the Arduino UNO. Now the Arduino receives the data and send the output as a warning. Warning is displayed on the LCD as well voice instruction is given through the speaker.

3.2 WORKING

- Here we use an MEMS sensor to receive the vibrations from the ground. This sensor checks the vibrations or movement of plates in X and Y coordinates. It checks the ground plates movements by considering the angle of elevation of sensor on the ground.
- The MEMS sensor receives the data and sends it to the Arduino micro controller, the microcontroller then processes the data and sends the output.
- The output from Arduino is given in two forms for the present working module i.e., audio as well as visual.
- The Visual output is given on the LCD screen as it displays the warning statement.
- A few seconds of warning is also given through the speaker to alert the people as a sign of the earthquake warning.

3.3 FLOWCHART OF THE PROJECT

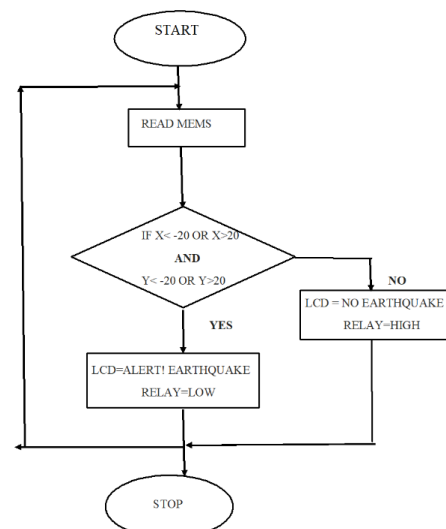

3.4 CIRCUIT DIAGRAM

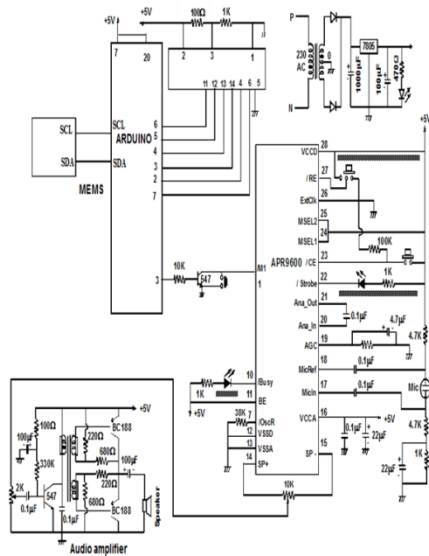

Fig. 3.: Circuit Diagram

In the above circuit diagram of Earthquake Detector, the main component is Arduino Uno. Input of the device is power supply and MEMS sensor, that receives the vibration from the ground. The output is displayed on LCD as well voice instruction is also given as the output. Therefore, the earthquake detector can be considered from above circuit diagram.

IV. SYSTEM ANALYSIS

4.1 EXISTING SYSTEM

Earthquake detection can be done only by particular organizations and particularly through specified devices. It is the natural disaster with takes the huge penalty of lives and huge property. Late warning of earthquake is causing these amount of loss. There is no domestic equipment that can detect the Earthquake and gives the early warnings.

4.2 PROPOSED SYSTEM

Here we use an MEMS sensor to receive the vibrations from the ground. This sensor checks the vibrations or movement of plates in X and Y coordinates. It checks the ground plates movements by considering the angle of elevation of sensor on the ground. MEMS Sensor is a ADXL345 accelerometer that detects the vibrations of the ground in two directions. We took the concept of angle of elevation for checking the movement of plates in the ground which is considered as the Earthquake. So it used as the input device in the proposed model. The MEMS sensor receives the data and sends it to the Arduino micro controller, the microcontroller then processes the data and sends the output. In the proposed model we tried to give some basic output which alerts people from Earthquake. The output from Arduino is

given in two forms for the present working module i.e., audio as well as visual. The Visual output is given on the LCD screen as it displays the warning statement.

A few seconds of warning is also given through the speaker to alert the people as a sign of the earthquake warning.

The proposed idea is designed in an embedded platform. ATMEGA 328 micro controller platform is used for developing this system. The micro controller will first check the input from the MEMS sensor. By analysing that condition the microcontroller will give the output through LCD and speaker.

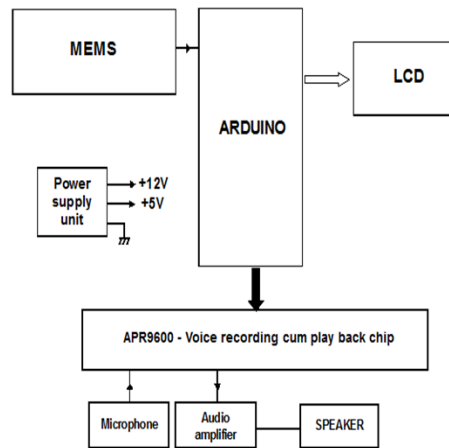

Figure 4: Proposed System Block Diagram

4.3 RESULT PHOTOS

4.3.1 EARTHQUAKE DETECTOR WITHOUT POWER SUPPLY

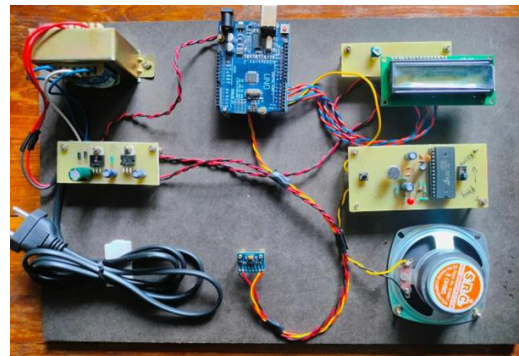

Figure 5: Earthquake detector without power supply

4.3.2 EARTHQUAKE DETECTOR WITH POWER SUPPLY

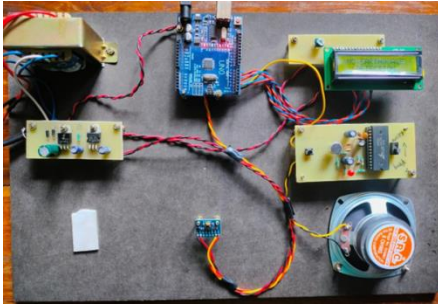

Figure 6 :Earthquake Detector with power supply

4.3.3 LCD SCREEN UNDER NORMAL CONDITIONS



Figure 7. LCD under normal conditions

4.3.4 LCD SCREEN DURING EARTHQUAKE

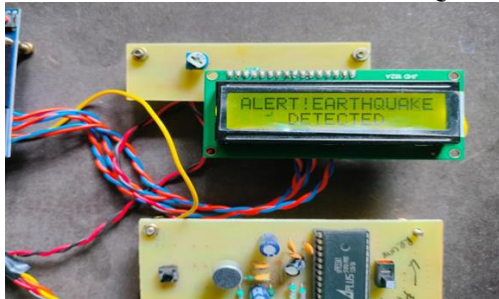

Figure 8 :LCD screen during Earthquake

4.4 APPLICATIONS

- The Earthquake Detector can be used in earthquake prone areas.
- It can be used at the domestic level.
- MEMS sensors are used in variety of applications like controlling, handling, manging robots etc.

4.5 ADVANTAGES

- It is a home safety device.
- Alerts people from earthquake before it happens.
- Affordable cost.

- Portable and handy.
- Circuitry is not complicated.

4.6 DISADVANTAGES

- Chances of getting false warnings.
- Warning may be transmitted before strong tremors occur.
- Velocity of earthquake can not be obtained.
- Movement of ground plates can not be sensed in all directions.

V. CONCLUSION & FUTURE SCOPE

5.1 CONCLUSION

The project work “Earthquake detector using Arduino and MEMS” is designed and developed successfully. For the demonstration purpose, a prototype module is constructed; and the results are found to be satisfactory. Since it is a prototype module, a simple module is constructed, which can be used for many remote applications.

While designing and developing this proto type module, we have consulted few experts, these professionals working at different organizations belongs to Hyderabad, helped us while building this module. Since it is a prototype module, much amount is not invested, the whole module is constructed with locally available components, and they are not up to the requirement. Some of the modifications must be carried out in design and is essential to make it as real working system.

This project revealed that building a relatively low cost, high precision earthquake warning system. The same system using suitable wireless communication technologies can transmit the information to the remote locations also.

5.2 FUTURE SCOPE

- The possibility of the project being able to detect changes in the all possible directions and angles makes the project effective one.
- The removal of occurring of false warnings can make the project a complete useful in the future.
- In future the Android based Earthquake detector using MEMS sensor will be best household safety device by rectifying the above defects.

BIBLIOGRAPHY

The following are the references made during the development of this project work.

Text Books:

- [1] Linear Integrated Circuits – By: D. Roy Choudhury, Shail Jain
- [2] Digital Electronics. By JOSEPH J.CARR
- [3] Fundamental of Radio Communication: By A.SHEINGOLD
- [4] Basic Radio and Television: By S.P.SHARMA

[5] Digital and Analog Communication System
By: K. sam Shanmugam

[6] Relays and their applications - By:
M.C.SHARMA

[7] The concepts and Features of Micro-
controllers - By: Raj Kamal

[8] The 8051 Micro-controller Architecture,
programming & Applications - By: Kenneth J. **Ayala**

[9] Programming and Customizing the 8051
Micro-controller - By: Myke Predko

[10] Electronic Circuit guide book – Sensors –
By JOSEPH J.CARR

Catalogs:

- (1) TEXAS - LINEAR IC's manual
- (2) SIGNETICS - DIGITAL IC's manual

Journals:

- (1) Electronic Design
- (2) Electronics for you
- (3) Electronics Text.
- (4) Practical Electronics