

ENHANCING CURRENT CONTROL IN SMALL-SCALE DC MICROGRID USING MULTI-LEVEL CONVERTER

¹T.Lingaiah,²J.Nageswara Rao,³M.Rajyalakshmi,⁴Yajala Harika

^{1,2}Associate Professor,³Assistant Professor,⁴Student

Department of EEE

G V R & S College of Engineering & Technology, Guntur, AP

ABSTRACT—Since multilevel converters provide the combination of low switching frequencies and good harmonic performance, they are interesting options for small-scale DC power networks. Replicated submodules may also be added to the cascaded converter chain to increase dependability. DC micro grids, with very low line impedance, are developing as the next generation of small-scale electric power networks. It is consequently essential for a power flow controller to have a quicker transient response and accurate power flow management since this phenomena generates high currents in the micro grids even for a little change in voltage. In order to achieve high speed and high accuracy power flow management in a dc micro grid, multi-level converters are used as the power flow controllers in this research. Because a multi-level converter is being utilised, the output filter may be tiny. In order to meet the need of current ripple, this project also provides the design of a multi-level converter's output LC filter. Compared to traditional two-level converters, we can confirm that a multi-level converter with a smaller filter can achieve high-speed and high-precision power flow management for low line impedance situations. MATLAB/Simulink Simulation results are used to assess the control performance of each output current in the step response while taking transient variations in the power flow into consideration.

I. INTRODUCTION

Inverters are very useful for various industrial applications. In the last few years, the voltage-driving method has been adopted. To reduce the semiconductor transient voltage and current rating, a series and parallel connection method is needed. Moreover, the limited standard three-phase converter is also adopted up to the maximum allowable voltage of the load. Also, both the primary and the Pulse width modulation (PWM) switching frequency can be useful. The reduced switching frequency shows the low disappearance and the higher efficiency. In order to synthesize the spectrum signals of the harmonics caused by the capacity, the multi-level inverter has received more attention in recent times. Moreover, a multilevel inverter has a key role in providing improved operating voltage beyond the voltage

limits of conventional semiconductors. For low power photovoltaic systems, the classical two-level inverter is typically employed as the interface between dc-link and grid. However, modern wind turbines, which range from hundreds of kilowatts up to a few megawatts, demand special converter structures. One alternative is to connect switching devices in series to cope with the high voltage stress. However, this technique requires a precise method to ensure the voltage share between the devices in dynamic and static situations. Another method that has been well accepted by the industry, and is emerging as the standard solution for high power medium voltage applications, is the Multilevel Converter. These structures have the ability to synthesize the output waveform from several levels of voltages, improving the spectrum quality when compared with the classical two-level topology.

A dc microgrid helps achieve efficient power transfer by reducing the number of power conversion stages between the ac and dc sides, because most grid-tied renewable energy systems deal with dc power on both input and output sides. Line impedances are usually very low in a dc microgrid owing to the shorter distances between the nodes such as the generators, batteries, and loads compared with a large scale ac grid; thus, a large current flows through the lines even for a slight change in voltage. To suppress the excess current, a two-level converter needs a bulky output filter. A part of a grid configuration connecting only two converters and a passive resistive load has been investigated. It proposes an efficient power flow sharing and voltage regulation control method based on a hierarchical control to minimize the transmission loss of the dc micro-grids. The circuit topology used for the above studies in has been mainly the two-level converter. Moreover, an improvement of the dynamic performance has not become their main objectives. Meanwhile, there are studies aiming the realization of the high-speed response of the individual converter. In a control method to realize the fast current response in a dc-dc converter was reported. This method assumes a lowvoltage power supply with conversion from 5.5 V to 3.3 V and a switching frequency in MHz range to be integrated on a chip or in a package. It proposed a predictive current control for a bidirectional two-level dc-dc converter to enhance the steady-state and dynamic performances of the

dc microgrid. In addition, there are studies dealing with the circuit topology of a two-level bidirectional converter for the dc microgrid. For the power converters on the dc microgrid, the conventional two-level topology has usually been adopted; however, the two-level topology has inherent limitations in achieving a higher switching frequency and a faster dynamic response.

To overcome these limitations in a microgrid, a converter with high speed and precise power flow control is required. However, with a large LC filter, power flow cannot change rapidly, even for a sudden change in the reference of the power flow and load conditions. In the present study, we apply a multi-level converter to realize higher speed and precise power flow control in a dc microgrid. An m -level converter can produce an output voltage with m -steps even without a filter. This clearly indicates that an m -level converter enables decrease of ripple content in a dc output voltage to $1/m$ th of that of the two-level converter; thus, as the level (m) increases, the output filter can become smaller. It has been studied to apply multi-level converter to dc micro grid. However, there are no studies that dc network is constructed by using multiple multi-level converters. In this study, the design procedure of the power flow controller for a dc small scale grid is investigated by dealing with the number of the levels as one of the design parameters. The contribution of this study is in the comprehensive design of the converters and LC filters for the dc micro grid based on the number of the levels. Moreover, experiments are conducted by constructing a dc network with multiple multi-level converters.

II. SYSTEM MODELING

A. Assumed Circuit

A circuit for the investigation of power flow between two nodes as the minimum part of a dc microgrid is shown in Fig. 1. In terms of power flow, a dc micro grid comprises three types of elements: a unidirectional power supply such as PV or wind, a bidirectional supply/load such as a battery bank, and unidirectional loads. These elements are connected one-to-one, one-to-plural, or plural-to-plural. In Fig. 1, E_1 , R_1 , E_2 , and R_2 represent the power supplies and loads that are connected through a distribution line and a power flow controller. Fig. 2 shows the circuit configurations of the two-level and multi-level topologies. In this study, flying-capacitor type multi-level topology is used as an example [17]–[20]. The numbers of the circuit components in each converter are listed in Table I. A flying capacitor type m -level converter consists of $(2m-2)$ switches and $(m-2)$ flying capacitors in the main circuit. Although the number of the series

connected switches increases in proportion to the number of the levels, the total conduction loss remains almost the same with that of the two-level converters. Because a switch with a lower voltage rating and lower on-state resistance can be applied in the multi-level converters due to the reduction of the voltage stress for each switch. From the viewpoint of the control, gate signals and the output switching frequency with the phase-shifted carrier modulation increase as the number of the levels increases. However, the number of the sensors does not increase in the control method of this study. In this way, there is a tradeoff relationship between the reduction of the circuit components and improvement of the output control performance. Therefore, a comprehensive design procedure considering the number of the levels and output filter is necessary, and it is clarified in this study.

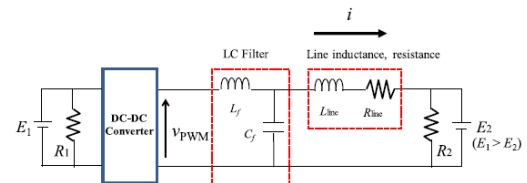

Fig. 1. Circuit for power flow control between two nodes.

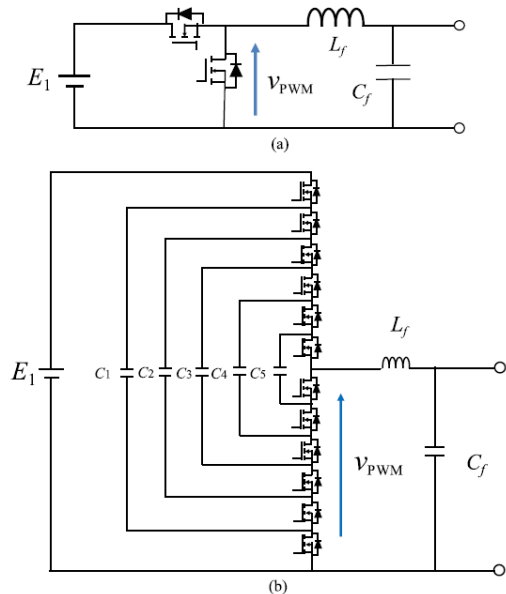

Fig.2. Circuit configurations of power flow controllers. (a) Two-level topology. (b) Multi-level topology (seven-level case).

TABLE I
NUMBER OF ELEMENTS IN CONVERTERS

The number of levels	2-level	7-level	m -level
Switching device	2	12	$2m-2$
Flying Capacitor	-	5	$m-2$
Output PWM switching frequency f_{PWM}	f_c	$6f_c$	$(m-1)f_c$

B. Theoretical Design Procedure for Power Flow Controller

Considering the Number of Levels The design of output filter of a power flow controller is performed with the objective to decrease both the current ripple (steady state) and the settling time (transient state) simultaneously; however, there is a tradeoff relation between them depending on the filter parameters that can be improved in the case of a multi-level converter to match the lower output ripple of the two-level converter. As the number of levels increases, the output LC filter becomes smaller and output response time decrease. Therefore, larger number of the levels provides improving the system dynamic behavior. However, the flying capacitor type m-level converter consists of a lot of the components such as $(2m - 2)$ switches and $(m - 2)$ flying capacitors compared with the two-level converters. There is tradeoff relationship between the number of the levels and improvement of the system dynamic behavior. Therefore, it is necessary to design in consideration of the number of the levels m . Fig. 3 shows typical waveforms to demonstrate the tradeoff between the ripple current and settling time in the two-level and multi-level converters. For the same ripple, the settling time is longer for the two-level converter (larger filter) than that of the multi-level converter (smaller filter), as shown in Fig. 3(a). On the other hand, for the same filter, the ripple is larger for the two-level converter than that of the multi-level converter, as shown in Fig. 3(b). The two level converter has an inherent constraint in design with regard to improving both the ripple and the settling time for the same switching frequency, e.g., that of a multi-level converter. In the design, the gradient of the current rise in a step response is analyzed instead of the settling time considering that the gradient is proportional to the settling time when the current response is optimized for critical damping.

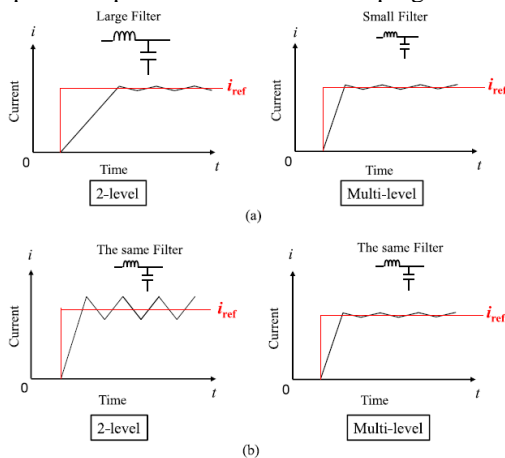

Fig. 3. Example of current waveforms in step response depending on the number of output levels and output filter of converters. (a) When both filters

are specifically designed for same ripple of output current. (b) When both filters have the same parameters.

The equivalent circuits for the analysis of the gradient and steady-state ripple of the output current considering the worst-case operation of the converter. Using theoretical investigations, the maximum gradient of the current change is determined by (1). For the sake of simplicity, R1 and R2 can be ignored

$$\max \frac{di}{dt} = \frac{E_1 - E_2}{L_{line} L_f C_f} \frac{1}{(\alpha - \beta)(\alpha - \gamma)}$$

Here, α , β , and γ are the solutions of s in the following equation, where β and γ are the conjugate values

$$s^3 + \frac{R_{line}}{L_{line}} s^2 + \left(\frac{1}{L_{line} C_f} + \frac{1}{L_f C_f} \right) s + \frac{1}{L_{line} L_f C_f} = 0.$$

The ac current is in the steady state can be determined by the (3)–(5). V_n is the n th order harmonics of vPWM. V_n is changed according to the number of levels (m). vPWM is the voltage, as shown in Fig. 2. The current ripple in the steady state can be calculated by taking the difference between the maximum and minimum values. Since i is periodic, the approximate maximum and minimum values can be obtained by calculation. The L_f and C_f are determined to satisfy the requirement of the current ripple for an application. The L_f and C_f of the filter and the output level (m) can be designed by numerical calculations using (1)–(5). In this way, the design procedure for the power flow controller and the filter is explained theoretically.

The current control capability of the two-level and multi-level converters are validated using a simulation. In this investigation, a distribution network comprising three nodes and three converters is considered as a part of the assumed dc microgrid, as shown in Fig. 4. In this circuit, three bidirectional power supplies are assumed the batteries. They are connected to one another through the respective power flow controllers and distribution line, whose stray inductance and resistance values depend on its length. Two types of the distribution network are constructed, one with three two-level converters and the other with three seven-level converters.

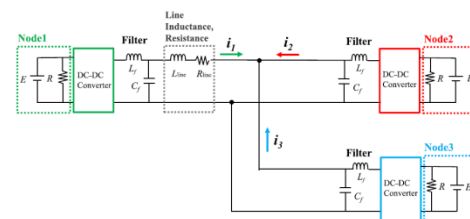

Fig. 4. Circuit configuration of distribution network with three nodes and three converters for validation of power flow control.

III. SIMULATION RESULTS

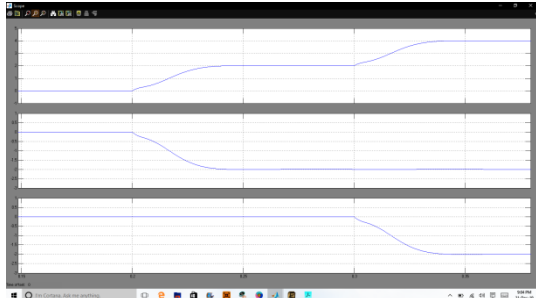

Fig:5- Simulation result of power flow using three two-level converters ($f_{PWM} = 500$ kHz).

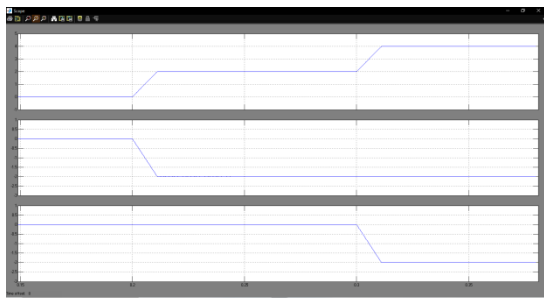

Fig:6- Simulation result of power flow using three seven-level converters ($f_{PWM} = 500$ kHz).

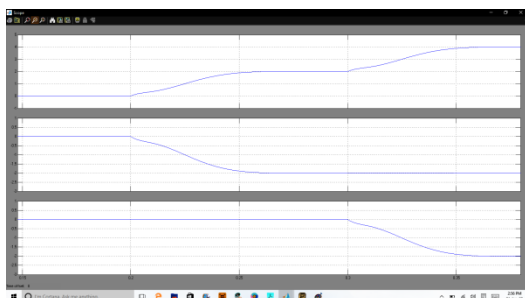

Fig:7- Simulation result of power flow using three two-level converters ($f_{PWM} = 83.3$ kHz).

First, all the currents are initially set to zero, which means that the output voltages of all the three converters are controlled to the same value. Second, a current of 2.0A from Node1 to Node2 is achieved by changing the output voltage of the converters, thereby fixing current i_3 at zero. Third, a current of 2.0A flows from Node1 to Node3, thereby fixing current i_2 at 2.0A. As a result, a current of 4.0A from Node1 is distributed equally (2.0A) to Node2 and Node3. The current-control scheme adopted in each converter is based on PI controller using the feedback information of each inductor current. Figs. 5 and 6 show the simulation results for the two-level and seven-level converters, respectively. It is observed that the settling time in the case of the seven-level converter becomes approximately one fifth that of the two-level converter, which is due to the lower

time constant of the filter of the seven-level converter. In addition, it is observed that the response values of i_2 and i_3 do not follow the reference values at the respective instants of the step change (0.2 and 0.3 s); this is due to the limitation of the response bandwidth of the converter. While the settling time in the seven-level converter improves five times, the peak value of the discordance (ripple) only doubles. This faster power flow capability of the multi-level converter is expected to provide higher stability and reliability of the dc microgrid. Since the output switching frequencies are equalized between the two-level and the seven-level converters, the total number of switching in each circuit is the same. However, for this condition, the switching loss of the two-level converter is larger than that of the seven-level converter; therefore, from the efficiency viewpoint, considering the same carrier frequency for both converters would be a practical approach for a fair comparison. Accordingly, the switching frequency of the two-level converter was changed from 500 to 83.3 kHz. Fig. 7 shows simulation result for the power flow using three two-level converters ($f_{PWM} = 83.3$ kHz).

CONCLUSION

In order to provide quicker current management in a dc microgrid with very low-impedance interconnections, we looked at multi-level converters in this work. The number of output levels, steady-state ripple, and gradient of the transient change in the output current were taken into consideration throughout the design process of the power flow controller's output filter. Through simulations and tests, the current-control performances of the two-level and seven-level converters were examined. According to the research, a power flow controller that fixes the current ripple at the same level and realises quicker current control uses a multi-level converter. Because they can manage power flows more quickly, multilevel power flow controllers are anticipated to have a substantial influence on small-scale dc distribution networks by increasing stability and dependability.

REFERENCES

- [1] L. Tang and B. Ooi, "Locating and isolating DC faults in multi-terminal DC systems," *IEEE Trans. Power Del.*, vol. 22, no. 3, pp. 1877–1884, Jul 2007.
- [2] F. Zhang *et al.*, "Power management strategy research for DC microgrid with hybrid storage system," in *Proc IEEE 1st Int. Conf. DC Microgrids*, Atlanta, GA, USA, 2015, pp. 62–68.

- [3] H. Kakigano, Y. Miura, and T. Ise, "Distribution voltage control for DC microgrids using fuzzy control and gain-scheduling technique," *IEEE Trans. Power Electron.*, vol. 28, no. 5, pp. 2246–2258, May 2013.
- [4] K. Natori, H. Obara, K. Yoshikawa, B. C. Hiu, and Y. Sato, "Flexible power flow control for next-generation multi-terminal DC power network," in *Proc. IEEE Energy Conver. Congr.Expo.*, 2014, pp. 778–784.
- [5] M. Brenna, E. Tironi, and Giovanni Ubezio, "Proposal of a local DC distribution network with distributed energy resources," in *Proc. 11th Int.Conf. Harmonics Quality Power*, 2004, pp. 397–402.
- [6] X. Yue, D. Boroyevich, F. C. Lee, F. Chen, R. Burgos, and F. Zhuo, "Beat frequency oscillation analysis for power electronic converters in DC nanogrid based on crossed frequency output impedance matrix model," *IEEE Trans. Power Electron.*, vol. 33, no. 4, pp. 3052–3064, Apr. 2018.
- [7] M. Wang, S. Tan, C. Lee, and S. Y. Hui, "A configuration of storage system for DC microgrids," *IEEE Trans. Power Electron.*, vol. 33, no. 5, pp. 3722–3733, May 2018.
- [8] M. Kwon and S. Choi, "Control scheme for autonomous and smooth mode switching of bidirectional DC–DC converters in a DC microgrid," *IEEE Trans. Power Electron.*, vol. 33, no. 8, pp. 7094–7104, Aug. 2018.
- [9] J. Ma, L. Yuan, Z. Zhao, and F. He, "Transmission loss optimization based optimal power flow strategy by hierarchical control for DC microgrids," *IEEE Trans. Power Electron.*, vol. 32, no. 3, pp. 1952–1963, Mar. 2017.
- [10] K. Hu and C. Liaw, "Incorporated operation control of DC microgrid and electric vehicle," *IEEE Trans. Ind. Electron.*, vol. 63, no. 1, pp. 202–215, Jan. 2016.